

Social Organization and Genealogy of Resident Killer Whales (*Orcinus orca*) in the Coastal Waters of British Columbia and Washington State

M. A. Bigg, P. F. Olesiuk, G. M. Ellis,

*Department of Fisheries and Oceans, Pacific Biological Station,
Nanaimo, British Columbia, Canada V9R 5K6*

J. K. B. Ford

Vancouver Public Aquarium, P.O. Box 3232, Vancouver, British Columbia, Canada, V6B 3X8

and K. C. Balcomb III

Center for Whale Research, Friday Harbor, Washington 98250

ABSTRACT

The social organization and genealogy of resident killer whales in the coastal waters of British Columbia and Washington State are examined based on field observations and analyses of photographs of recognizable individuals collected during 1973–87. All individuals were identified in two communities, with 261 animals alive in 1987. The membership of social groups is determined by observing which individuals travel most frequently together and by examining the relative strength of bonds among individuals within groups. The strength of bonds is established from direct observations of the proximity of individuals to one another and from an analysis of the association of individuals in photographic sequences. The social organization is classified into communities, pods, subpods and intra-pod (matrilineal) groups. A community comprises individuals that share a common range and associate with one another; a pod is a group of individuals within a community that travels together the majority of the time; a subpod is a group of individuals that temporarily fragments from its pod to travel separately; an intra-pod group consists of a cohesive group of individuals within a subpod that always travels in close proximity. Communities contain 3–16 (mean=9.5) pods; pods contain 1–3 (mean=1.7) subpods, subpods contain 1–11 (mean=1.9) intra-pod groups and intra-pod groups contain 2–9 (mean=3.6) individuals. The membership at each group level was stable during the study, except for births and deaths. No dispersal of individuals or groups was observed.

Genealogical trees within pods are constructed from known genealogies and from inferences about genealogy based on the strength and continuity of bonds among pod members. The genealogical trees indicate that intra-pod groups are matrilineal. A matrilineal group typically comprises of 2–3 generations (range 1–4; mean=2.3) and a generalized matrilineal group consists of a grandmother, her adult son, her adult daughter and the offspring of her daughter. Matrilineal groups are the basic unit of social organization. New matrilineal groups appear to form by splitting along maternal lines. Subpods and pods appear to be comprised of related matrilineal groups and probably form through the gradual splitting of their natal subpods or pods along matrilineal group lines. Pod-specific dialects suggest that related pods eventually associate randomly. Pods are grouped into four acoustic (but not social) clans. Pods within each clan are likely to have a distant common ancestor.

The lack of dispersal of the resident form of killer whale from their natal groups appears to be unique among mammalian social systems. However, dispersal appears to occur in the transient form, which also differs in physical appearance, distribution and behaviour. The two forms may have evolved after adopting different foraging strategies. This species has the potential to have developed many local races over its cosmopolitan range, with each race having unique social and behavioural characteristics.

1. INTRODUCTION

Numerous studies on the biology of killer whales (*Orcinus orca*) in the coastal waters of British Columbia and Washington State have been facilitated by the fact that all individuals can be recognized from unique natural markings. These studies have provided information on abundance, movements, behaviour, feeding habits, vocalizations, social organization, life history and population dynamics (Balcomb, Boran and Heimlich, 1982; Bigg, 1982; Ford and Fisher, 1982; 1983; Balcomb and Bigg, 1986; Haenel, 1986; Heimlich-Boran, J.R., 1986; 1988; Heimlich-Boran, S.L., 1986; Jacobsen, 1986; Bigg, Ellis, Ford and Balcomb, 1987; Olesiuk and Bigg, 1990).

An important finding of these studies regarding social organization was that two forms of killer whale, termed 'resident' and 'transient', inhabit this region. The resident form comprises a northern and southern community, whereas the transient form is a single community that is sympatric with but does not mix with the two resident

communities. The resident form is the most abundant comprising about 75% of all individuals identified. Resident whales travel in long-term groups known as pods. It has also been noted that there are groupings within pods (Bigg, 1982).

In recent years, we have focused our studies on the social organization and genealogies of pods within the two communities of resident killer whales. Bigg *et al.* (1987) summarized some of these findings in a popular account on the biology of killer whales. In this paper we examine social organization and genealogies using field observations and photographs collected during 1973–87. The identity and individual membership of each pod and the social structure within pods was determined by observing which individuals travelled together most often and by examining the relative strength of bonds among individuals within groups. The relative strength of bonds was determined from: (1) direct observation of the proximity of individuals to one another as seen during field observations and in photographs; and (2) an index of the degree of association among individuals in photographic sequences. The individuals within each

pod are described in a registry that listed their name code, group affiliations and, where known, their sex, year of birth, year of death and their mother's identity.

Maternal genealogical trees were constructed based on known mother-offspring genealogies and genealogies inferred from the strength and continuity of bonds among individuals. The likely genealogies among pods were examined based on the relative degree of association of pods and on pod-specific dialects. The significance of genealogy in the social organization of the resident communities is discussed and the social organization of the resident and transient forms compared.

The results presented in this study describe the social organization and likely genealogies of all individuals within the two communities. The methods utilized may be applicable to other long-term studies of killer whales and to other species. This report provides a framework for additional killer whale studies. For example, the genealogies given here are used in an analysis of the life history and population dynamics of resident killer whales (Olesiuk and Bigg, 1990) and the data can be used in on-going sociobiological studies.

2. DATA COLLECTION AND ANALYSIS

2.1 Study area and duration

Studies were conducted in the inshore waters of British Columbia and Washington State. Whales were encountered most frequently in Johnstone Strait and Haro Strait (Fig. 1), two core areas where the northern and southern communities, respectively, congregate during summer months. Whales were also observed at many other sites off eastern Vancouver Island and in Puget Sound, but only occasionally north of Vancouver Island and off the west coasts of Vancouver Island and Washington State. Most encounters were within 10km of shore, but some were as far as 30km offshore.

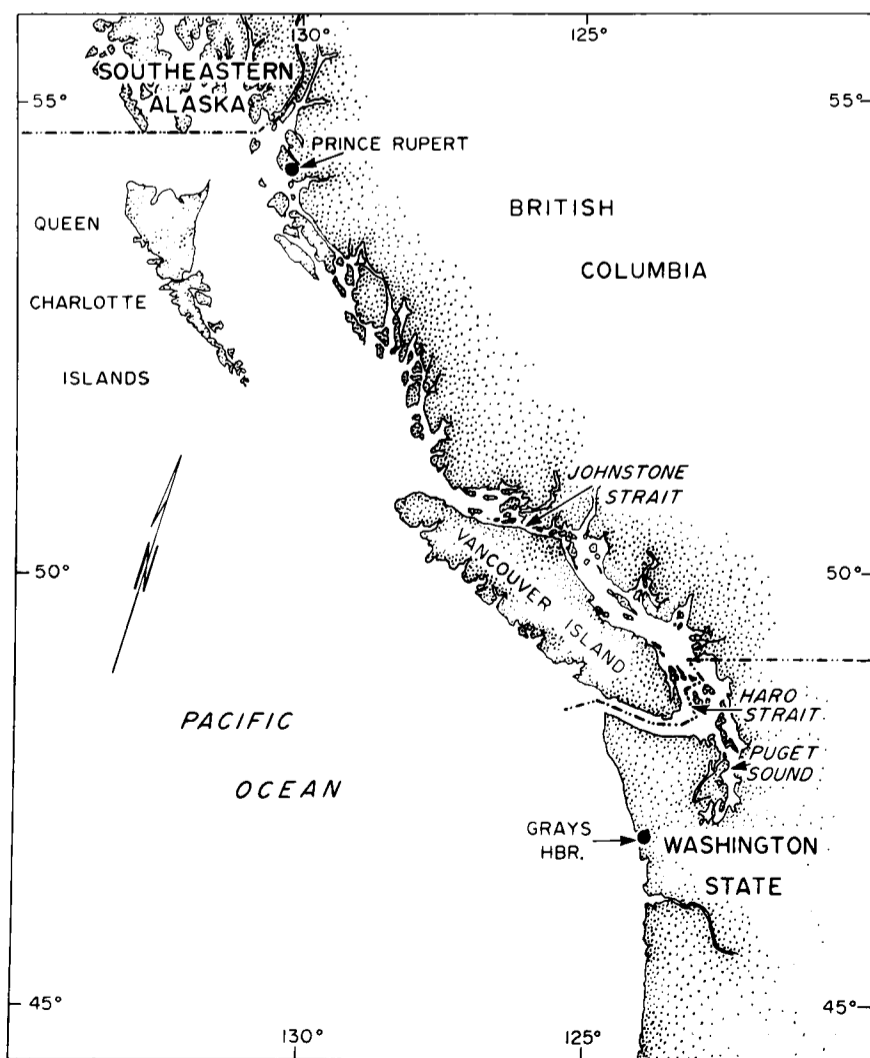

Fig. 1. Geographical names in British Columbia and Washington State referred to in the text.

The study began in Johnstone Strait in 1973 and was expanded to include most areas off eastern and southern Vancouver Island in 1974, Puget Sound in 1976 and then to other coastal areas of British Columbia and Washington State. Whales were encountered in all months, although mainly during July to September (Fig. 2a). Data were collected annually, for the northern community from 1973 and for the southern community from 1974 (Fig. 2b). The analyses here include data obtained up to the end of 1987. The unusually large number of encounters in 1986 was provided mainly by other researchers who kept almost daily records of the identity of pods seen in Johnstone Strait during the summer months.

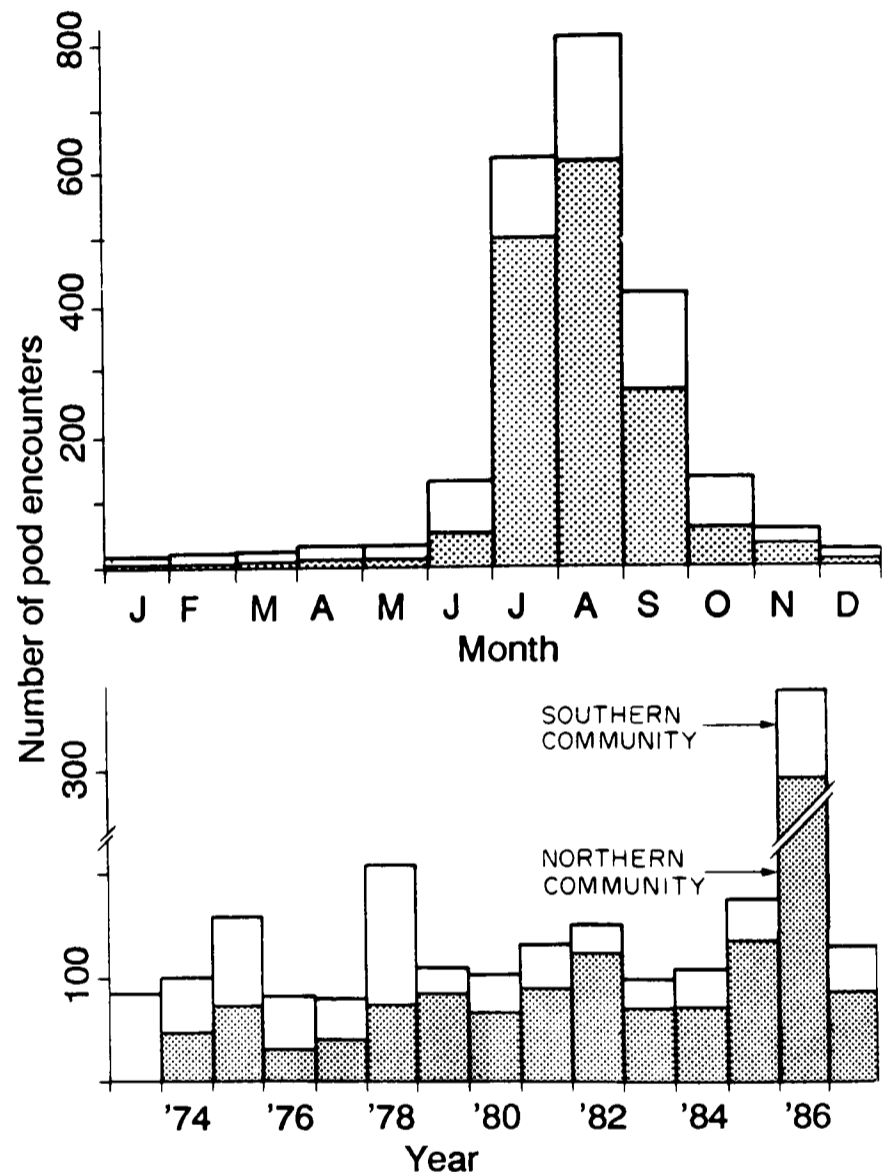

Fig. 2. Number of pod encounters with pods belonging to the northern and southern communities during 1973-87: (a) by month and (b) by year. The number of pod encounters represents the product of the total number of encounters and the number of pods present during each encounter.

The start of the study for each pod was defined as the first year in which all members of the pod were identified: 1973 for pods A01, A04, A05, B01, C01 and D01; 1974 for pods J01, K01 and L01; 1975 for pods G01, G12, H01, I01, I02, I11, I18, I35 and R01; and 1979 for pod W01. In some cases, data collected for pod members prior to these years were used because they provided information on ages and reproductive histories.

2.2 Individual identification and nomenclature

Individuals were identified from the unique appearance of their dorsal fin, saddle patch and back when viewed laterally, usually from the left side. The distinctive features included the relative size, shape and outline of the dorsal fin, saddle patch and back, as well as scratches, nicks, gouges and blemishes. Most individuals were recognizable

by eye, but some required a good photograph for positive identification. The distinctive features of individuals in the study region were shown in three field guides (Sugarman, 1984; Bigg *et al.*, 1987; Osborne, Calambokidis and Dorsey, 1988).

Each whale was assigned an alpha-numeric code. A single letter designated its pod and a two-digit number its identity within the pod. Pods were named after one of their members, generally the most distinctive individual. Several pods shared the same letter designation, such as pods A01, A04 and A05. The members of these pods also shared the same letter designation. For example, pod A01 contained individuals A01, A06, A33 and others, pod A04 contained individuals A04, A11, A52 and so on.

2.3 Field procedures

Whales were encountered mainly by waiting in core areas, such as Johnstone Strait and Haro Strait. They were located in other areas with the help of a network of volunteers who reported sightings by telephone. Observations were made from 5–7m power boats. During an encounter, each individual was usually photographed several times from a distance of 15–30m. We used a 35mm SLR camera equipped with an auto-film winder, a 300mm telephoto lens, a shoulder brace (Bigg, Ellis and Balcomb, 1986) and black and white film, either *Kodak TriX Pan* or *Ilford HP5* (preferred) exposed and processed at ISO 1600. Members of the southern community were identified in a total of 22,768 photographs and members of the northern community in 21,034 photographs. Throughout the study, each photographic frame was examined numerous times with a dissecting microscope to ensure that all individuals had been correctly identified (Bigg *et al.*, 1986).

During an encounter, we recorded the total number of individuals present, the identity of individuals that could be recognized by eye, individuals that were missing from their pod, the relative distances separating each individual and the body size of individuals relative to that of fully grown females and males. The identity of known mother-offspring pairs was also noted. A calf was considered to be the known offspring of an adult female if the calf was born during the study and travelled in very close contact with a particular adult female. Most calves were assigned to mothers when they were 0.5 years (85%) of age, but some were assigned to mothers at 1.5 (8%) or 2.5–5.5 years (7%). Underwater vocalizations were often recorded with a hydrophone to establish which pods were present based on pod-specific dialects (Ford and Fisher, 1982; 1983). Other researchers (see Acknowledgments) studying killer whales in the area also contributed photographs and similar observations.

2.4 Life history parameters

It is important to know the sex and age of individuals in order to establish genealogies. Several life history parameters described in Olesiuk and Bigg (1990) are summarized here to indicate how individuals were sexed and aged. Females attain the lower range of adult-size at about 10 years of age and typically give birth to their first viable calf (a calf that survives to 0.5 years of age) at 15 years of age. Females are typically reproductively senescent by age 40 years, although longevity sometimes extends to 80–90 years. Males grow more rapidly and by about 8 years approach the lower size range of adult females. Mature males can be distinguished from juveniles and adult females by the height to width ratio (HWR) of

their dorsal fin, which typically exceeds 1.4 by 15 years of age. The dorsal fin of males continues to grow to an asymptotic HWR of 1.6–1.8 by about 21 years, although males sometimes live up to 50–60 years.

The sex, age and other data on each individual are listed in Appendix Tables A and B. The year that an individual was first seen usually coincided with the year in which all members of its pod were identified. However, some individuals were identified in photographs taken by the public, naturalists and aquaria personnel as early as 1965. The year of death was considered to have been the year it disappeared from its pod. A range of years was given when several years lapsed between the time that the whale was last seen and the next complete census of its pod. The interval between the first and last year on arrival was seen provides a general indication of the amount of data for the individual.

2.4.1 Sex determination

The sex of most juveniles could not be determined except in cases where the penis or the unique pigmentation pattern of the genital region was observed (Bigg *et al.*, 1987). Individuals were classified as physically mature females when they attained the lower size range of an adult female and there was no apparent body growth or increase in HWR over a period of at least 4–5 years. Physically mature females that gave birth during the study or were accompanied by offspring were classified as sexually mature. Individuals whose dorsal fin attained an HWR of at least 1.4 were classified as sexually mature males. Males were considered to be physically mature once their dorsal fin reached its asymptotic HWR of 1.6–1.8.

2.4.2 Relative ages

The year of birth for most calves born during the study was known because adult females were usually encountered each year and the presence of new calves noted. In a few cases, the calves of females not encountered every year may not have been born in the year in which they were first encountered. In such cases, the year of birth was estimated based on the body size of the calf when first seen compared to that of known-aged juveniles. Juveniles grow rapidly during the first few years and can be aged by size up to about 3 years of age. A range in birth years was noted when a calf was judged to have been born in either of 2 years. Small juveniles estimated to have been born 1–3 years prior to the start of the study for their pod (Section 2.1) were similarly aged based on their size when first seen.

The year of birth of juveniles aged >3 years at the start of the study was estimated by subtracting the mean age of maturity (15 years for both sexes) from the year they matured. Females were considered to have matured in the year they gave birth to their first viable calf and males in the year in which their dorsal fin attained an HWR of 1.4. Seven juveniles aged >3 years (A16, A24, K40, B04, B20, R04, W05) at the start of the study were aged on the basis of their relative body size when first seen because the above ageing techniques were not applicable.

The year of birth of males that were sexually but not physically mature at the start of the study was estimated by subtracting the mean age of physical maturity (21 years) from the year their dorsal fin attained its asymptotic HWR. The year of birth of males that were physically mature at the start of the study could not be determined. However, we calculated their minimum ages by assuming that they had attained physical maturity in the year they were first

seen. Photographs of 11 physically mature males taken prior to the start of the study provided improved estimates of minimum ages.

The year of birth of females that were mature at the start of the study was established in conjunction with the construction of genealogical trees (Section 4.1). We assumed that a female's oldest assigned offspring was her first viable calf. The year of birth of the mother was estimated by subtracting 15 years from the estimated year of birth of her oldest offspring. These represented minimum ages because the oldest progeny may have died or been cropped (Section 3.2) prior to the start of the study. The reproductive status of mature females provided another indication of their relative age. Females that had not given birth for a decade or more were likely to be post-reproductive (Olesiuk and Bigg, 1990) and older than reproductive females. Given the potential inaccuracies in these age estimates, the ages were used conservatively in the construction of genealogical trees.

Olesiuk and Bigg (1990) derived ages for mature females using probabilistic correction factors based on natural mortality rates and other life history parameters. These age estimates are considered to be the most accurate available and are thus included in Appendix Tables A and B. However, they were not considered in the construction of the genealogical trees because they were based on the genealogies established in this study. Bigg *et al.* (1987) previously estimated the actual ages for some old mature females by assuming that their offspring were born during the mid-portion of their reproductive lives. These ages differed only slightly from those of Olesiuk and Bigg (1990).

2.5 Social groups and relative bond strengths

The membership of social groups and the relative strength of bonds among individuals within the groups were determined using a combination of direct observations and an association analysis. Both methods were used because neither alone was suitable in all cases. Direct observations were particularly useful for establishing the membership of social groups and the strength of bonds of individuals for which there were few photographs. However, association analysis was more useful for quantifying the strength of bonds and for establishing subtle bonds that could not be detected by direct observation.

2.5.1 Direct observations

We determined the membership of social groups by observing which individuals travelled most frequently together. These social groups were evident from observations in the field and from an examination of photographs with more than one individual present. The relative strength of bonds among group members was also recorded from observations in the field and from an examination of photographs. Individuals that consistently surfaced within 1–2 body lengths (5–10m) of each other were considered to be the most strongly bonded, whereas individuals within a social group that rarely surfaced in the vicinity of one another were considered to be the most weakly bonded.

One of our main research priorities during 1978–87 was to establish the membership of groups within pods and the relative strength of bonds among pod members. This was a cumulative process. The existence of pods and smaller groups became apparent during the 1970s (Bigg, 1982) and the identity and membership of almost all of the smaller

groups had been established by the early 1980s. The group memberships and relative strengths of bonds among group members were also compared with those determined from earlier versions of the association analysis (mainly early 1980s). If a new group membership or bond strength indicated by the earlier association analysis was confirmed by direct observation, we considered the new finding to have been established by direct observation. The comparisons made later in this report between direct observations and association analyses included much more data than were available for the earlier versions of association analysis. Only minor revisions of group memberships and bond strengths were necessary after the early 1980s.

The membership and stability of the groups have been frequently re-assessed in recent years. Photographs that contained more than one individual were particularly important for determining group membership and the relative strength of bonds among individuals early in the study before extensive field observations had been made. Direct observations were considered the most reliable source of information on associations, although these observations were continuous and not suited to a quantitative analysis.

2.5.2 Association analysis

Photographic sequences also provided information on the membership of social groups and relative bond strengths. Individuals that travelled in the same groups tended to occur in the same or adjacent photographs more often than individuals in different groups. Group members that travelled in close proximity tended to occur in such photographs more often than those that travelled distantly from one another. The photographic data were prepared for analysis by sorting frames into the sequence in which they were taken. The identity of all individuals in each frame or, optionally, in the ± 1 or ± 2 adjacent frames, was tallied for each encounter. Photographic frames or sequences that contained less than two individuals were deleted because they provided no information on association. Data from the remaining frames were accumulated in 2×2 contingency tables for each pair of whales for all years in which both individuals were photographed:

		First Individual		
		present	absent	total
Second Individual	present	a	b	a + b
	absent	c	d	c + d
	total	a + c	b + d	n

where $a+c$ and $a+b$ denote the total number of occurrences of the first and second individuals respectively, a the number of joint occurrences and d the total number of frames in which neither whale occurred in years in which both were photographed.

The degree of association between individuals was measured using Cole's (C_7 in Cole, 1949) association index (CAI):

$$CAI = \frac{ad - bc}{(a + b)(b + d)} \text{ for } ad \geq bc$$

$$CAI = \frac{ad - bc}{(a + b)(a + c)} \text{ for } bc > ad \text{ and } d \geq a$$

$$CAI = \frac{ad - bc}{(b + d)(c + d)} \text{ for } bc > ad \text{ and } a > d$$

which, expressed as a percent, ranged from -100 to +100 with a value of 0 indicating that individuals were randomly distributed in the photographs.

The CAI differs from most association indices in that it measures complete association (see Kendall and Stuart, 1967). Values of +100 occur only when the joint number of occurrences equals the number of occurrences of the less frequently identified individual (i.e. a equals the lesser of $a+b$ and $a+c$). In contrast, most other indices measure absolute association and give values of +100 only when both individuals always occur together (i.e. a equals $a+b$ and $a+c$).

An index of complete association was more appropriate because not all individuals were equally identifiable. Thus, an index of absolute association would have been biased in that individuals identified in many photographs would have tended to have higher associations than indistinctive individuals identified in few photographs. For example, an index of absolute association would tend to underestimate the degree of association between calves and their mothers, which always travelled together, merely because the calves were usually not well marked and had been identified in fewer photographs than the mother. In contrast, the CAI index would accurately indicate the high degree of association between calves and their mothers because the index is scaled according to the number of photographs of the calves.

CAI values were calculated for all pairs of individuals within each community for the periods 1973-76, 1977-80, 1981-84, 1985-87 and for all years combined. Because of the volume of these tabulations, only CAI values calculated for ± 1 frame and all years combined are presented. Nevertheless, CAI values in the other year groups were also used to examine bond strengths, especially when discrepancies existed between the association analysis and direct observations.

The membership of social groupings was identified from dendrograms constructed using an agglomerative average single-link algorithm (Johnson, 1967). In this procedure, the CAI values among all possible pairs of individuals were compared and the pair with the highest CAI linked. Next, the pair of unlinked individuals with the highest CAI were linked, or an unlinked individual with a higher mean CAI value with previously linked individuals was linked to that pair, and so forth until the mean CAI dropped to +15%.

The degree of association between the groups linked at $\geq 15\%$ CAI was measured using the point correlation coefficient (PCC):

$$PCC = \frac{ad - bc}{\sqrt{[(a+b)(a+c)(b+d)(c+d)]}} \text{ (Poole, 1974)}$$

where a represents the number of photographs containing one or more members of both groups, b and c the number containing members of only one of the groups, and d the number containing no members of either group. Expressed as a percent, the PCC index also ranged from -100 to +100 with 0 indicating random association.

The PCC measures absolute association. There were two reasons for switching from an index of complete association at the individual level to an index of absolute association at the group level. First, the individuals linked at $\geq 15\%$ CAI value represented intra-pod groups (Section 3.4) that always travelled together, whereas the intra-pod groups sometimes travelled separately from one another. Second, individuals differed more in their identifiability than did the groups. Thus, an individual within a group that

was photographed more often than another individual in the same group indicated that it was more identifiable and thus an index of complete association was preferable. On the other hand, a group that was photographed more often than another group indicated that it was travelling independently of the other and thus an index of absolute association was preferable.

One important property of the CAI was that it gave equal weighting to all joint occurrences of whales in photographs. However, whales in a frame were not necessarily equally associated. In a frame containing three individuals, two may have been in close proximity to one another with a third off in the distance. CAI would underestimate the degree of association between the two close individuals and overestimate their degree of association with the third distant individual. Thus, CAI tended to dampen the differences in the strength of bonds among individuals. The potential bias was most prevalent early in the study because a panoramic photographic style was occasionally used. Consequently, the CAI values of individuals that died early in the study tended to be higher and not directly comparable to individuals present throughout or born late in the study. This problem was circumvented by comparing the CAI values for these individuals for the period 1973-76 or by determining bond strengths from direct observations.

3. SOCIAL ORGANIZATION

We classified social organization into a series of progressively smaller groups referred to as communities, pods, subpods and intra-pod groups. Before defining and characterizing each level of organization, some general comments can be made about the behaviour and composition of these groups. Except for births and deaths, we observed no seasonal or long-term change in the membership within any level of social organization. In addition, no instances of immigration or emigration were observed at any level. Groups at each level were composed of individuals of mixed age and sex (Appendix Table A-B). It should be noted that the size of groups in tables and figures (e.g. Figs 4-5, Table 1, Appendix Tables A-B and Appendix Figs A-T) represent the cumulative memberships over all years of the study. In reality, groups tended to be smaller in any given year because some members died or were born during the study. However, the average sizes given in the text refer to the mean size for each year. The social organization is summarized in Table 3.

3.1 Communities

A community was defined as an assemblage of individuals that resided in the same area and periodically associated with one another. The resident whales in the area comprised two communities termed the southern community and the northern community. Individuals within one community did not associate with those in the other and only rarely entered the range of the other. Additional encounters have now refined the geographic ranges of the two communities (Fig. 3) since they were first described (Bigg, 1982). The range of the southern community extends from slightly south of the mid-latitudes of eastern and western Vancouver Island, around southern Vancouver Island, into Puget Sound and south to Grays Harbor on the west coast of Washington State. The range of the northern community extends from the northern

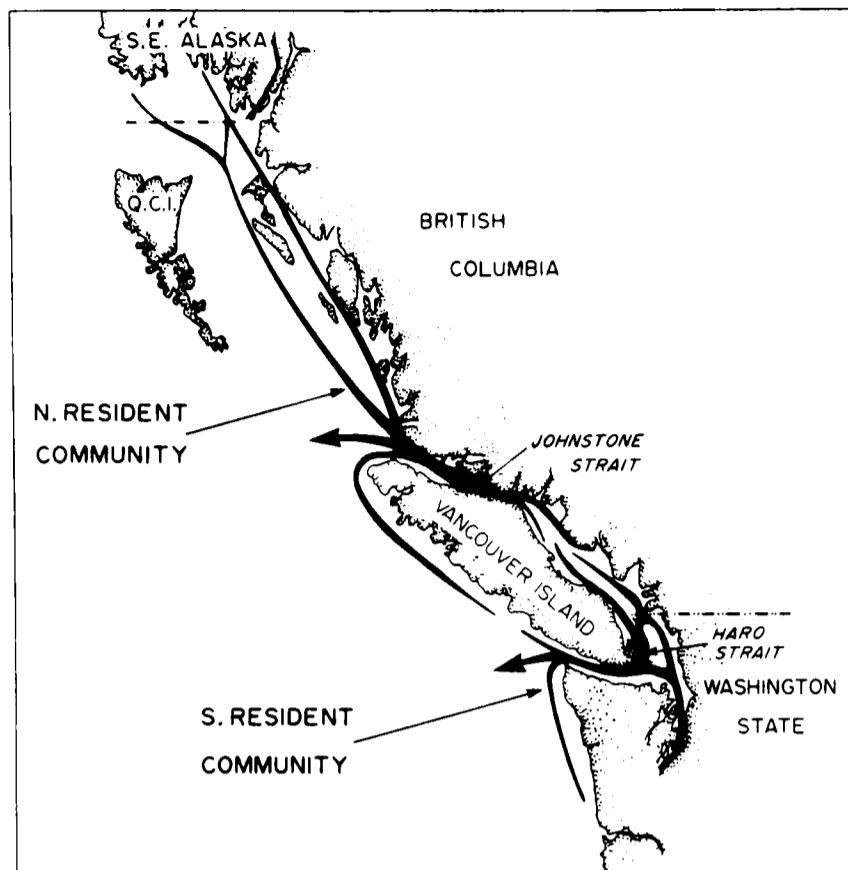

Fig. 3. Geographic ranges of the southern and northern resident communities.

border of the southern community around northern Vancouver Island, along the mainland coast of British Columbia and into southern Southeast Alaska. The community has not been observed off the Queen Charlotte Islands which suggests that it rarely, if ever, ventures there.

Whales in both communities undertake local seasonal movements, but not extensive migrations; they have been observed in the study area in all months of the year (Fig. 2a). However, they were observed most often during summer when they gathered in narrow coastal channels to feed on salmon. They apparently reside mainly offshore during winter-spring.

The southern community comprised 112 identified individuals and the northern community 215 individuals (Table 1). The individuals identified in each community represented virtually all that survived to 0.5 years of age. Olesiuk and Bigg (1990) estimated that only about one (1.2) viable calf would have died not having been identified.

One individual (J24) in the southern community and five (A16, A17, A18, C11, C15) in the northern community were photographed prior to the study, but were not present at the start. All were removed in the live-capture fishery, except for C15 which apparently died before the study began. These individuals were included in the analyses because they provided information on the ages and reproductive histories of their mothers, which were identified from early photographs and were still alive at the start of the study.

3.2 Pods

A pod was defined as the largest cohesive group of individuals within a community that travelled together for the majority of time (i.e. the largest group that travelled together for at least 50% of the time, or conversely the largest group that fragmented less than 50% of the time). The membership of pods was established over many years by observing which individuals most often travelled together. Memberships were supported by pod-specific

Table 1

Identification codes for the 19 pods and 329 individuals identified in the southern and northern communities during 1973-87. Six additional individuals that were cropped for aquaria or had died prior to the start of the study, but whose mothers were alive during the study, are shown in italics.

Southern Community

J01:

J01, J02, J03, J04, J05, J06, J07, J08, J09, J10, J11, J12, J13, J14, J15, J16, J17, J18, J19, J20, J21, J22, J23, *J24*;

K01:

K01, K02, K03, K04, K05, K07, K08, K11, K12, K13, K14, K15, K16, K17, K18, K19, K20, K21, K22, K30, K40, K46;

L01:

L01, L02, L03, L04, L05, L06, L07, L08, L09, L10, L11, L12, L13, L14, L15, L16, L20, L21, L22, L23, L25, L26, L27, L28, L32, L33, L35, L36, L37, L38, L39, L41, L42, L43, L44, L45, L47, L48, L49, L50, L51, L52, L53, L54, L55, L56, L57, L58, L59, L60, L61, L62, L63, L64, L65, L66, L67, L68, L69, L71, L72, L73, L74, L75, L76, L77;

Unknown: B20

Northern Community

A01:

A01, A02, A03, A06, A12, A20, A30, A31, A32, A33, A34, A36, A37, A38, A39, A40, A44, A46, A50;

A04:

A04, A10, A11, A13, A19, A24, A35, A41, A45, A47, A48, A49, A52;

A05:

A05, A07, A08, A09, A14, A15, *A16*, *A17*, *A18*, A21, A23, A25, A26, A27, A28, A29, A42, A43, A51;

B01:

B01, B02, B03, B05, B06, B07, B08, B10, B11, B12, B13;

C01:

C01, C02, C03, C04, C05, C06, C07, C08, C09, C10, *C11*, C12, C13, C14, *C15*;

D01:

D01, D02, D03, D04, D05, D07, D08, D09, D10, D11, D12, D13, D14, D15, D16;

G01:

G01, G03, G04, G05, G06, G07, G09, G11, G16, G17, G18, G19, G20, G22, G23, G24, G25, G26, G29, G30, G31, G32, G37, G38, G39, G40;

G12:

G02, G08, G12, G27, G28, G33, G34, G35, G36, G41, G42;

H01:

H01, H02, H03, H04, H05, H06, H07, H08;

I01:

I01, I03, I19, I23, I40, I54, I56;

I02:

I02, I05, I08, I14, I22, I28, I39, I55;

I11:

I04, I10, I11, I12, I13, I15, I16, I27, I37, I41, I42, I43, I44, I47, I51;

I18:

I07, I17, I18, I20, I21, I24, I26, I38, I48, I49, I50, I52, I53;

I31:

I31, I32, I33, I35, I36, I45, I46;

R01:

R01, R02, R03, R04, R05, R06, R07, R08, R09, R10, R11, R12, R13, R14, R15, R17, R18, R19, R20, R21, R22, R23, R24, R25;

W01:

W01, W02, W03, W05;

Unknown: B04

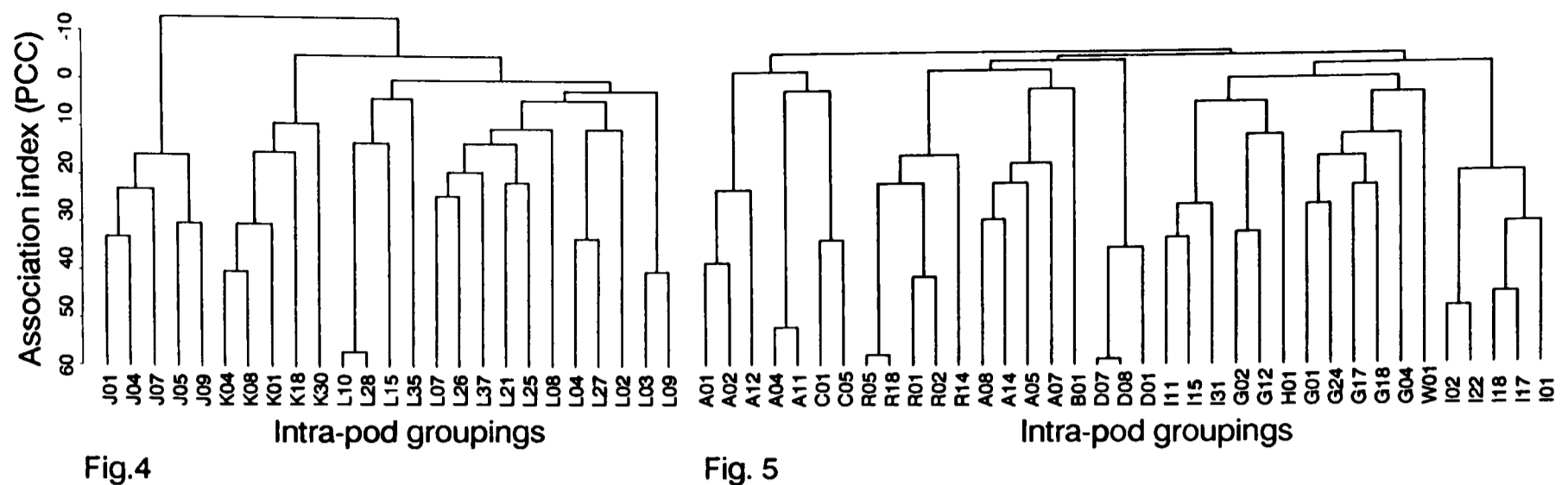

Figs 4 and 5. Dendrograms showing associations of intra-pod groups in the southern community (Fig. 4) and the northern community (Fig. 5). The dendrograms are based on the point correlation coefficient (PCC).

dialects (Ford and Fisher, 1982; 1983) and each pod formed a distinct cluster in the association dendrograms (see Figs 4–5 using pod compositions from Table 1).

The southern community was composed of three pods and the northern community of 16 pods (Table 1). The pods designated as A01, A04, A05, B01, C01, D01, H01, I11, J01, K01, L01 and R01 corresponded to those given in Bigg (1982). However, based on additional data, we divided Bigg's (1982) pod G into pods G01 and G12 and his pod I1 into pods I01, I02, I18 and I31. We also revised the size of pod W01. The pods for one individual from the southern community and one from the northern community could not be determined. One calf (B20) was first identified after it had become separated from its pod (Jeune, 1979) and a large juvenile (B04) died within a few days of being identified.

The membership of pods was stable over many years. Bigg (1982) noted that four individuals (J03, J04, J05 and J08) in pod J01 remained in the same pod for at least 13 years. Current data indicate that the same individuals remained together for at least 19 years.

Several resident pods were cropped for exhibits in zoos and aquaria during 1964–73 (Bigg and Wolman, 1975; Bigg, 1982). A total of 34 individuals were known to have been removed from the southern community and 14 from the northern community. All but two of the latter were taken from pod A05. In addition, 14 animals were taken from unknown pods off southern Vancouver Island and one from an unknown pod off northeastern Vancouver Island. These 15 whales may have been removed from either resident or transient pods. However, most were likely to have been taken from resident pods because this was the most abundant form and 90% of the cropped animals of known form were residents. Olesiuk and Bigg (1990) give data on the pod, sex and age of the cropped whales.

3.3 Subpods

Although some pods (e.g. B01, G12, H01, I01, I02, I31, J01, W01) never or rarely (<5%) fragmented into smaller groups, others (A04, A05, I11, I18, K01, L01 and R01) occasionally (5–24%) separated and a few (A01, C01, D01, G01) commonly (25–49%) fragmented. When pods fragmented they generally split into stable units which we termed subpods. Subpods usually separated from their pod for less than a month. They were named after one of their members. Pods comprised 1–3 (mean=1.7) subpods.

The membership of subpods was established (Appendix Table A-B) in the same manner as for pods. The discreteness and membership of subpods was also evident in the association dendrograms (Figs 4–5). In most cases (30 of 32), subpods formed distinct clusters in the dendrograms. The two exceptions were intra-pod groups (defined below) K18 and A05. Direct observations indicated that K18 should have linked to intra-pod group K30 before rather than after intra-pod groups K04–K08–K01. Direct observations also indicated that intra-pod group A05 should have linked to intra-pod group A08 before rather than after intra-pod group A14. Both misplaced intra-pod groups contained adult males, which tended to make intra-pod groups more independent (Section 4.1.4).

3.4 Intra-pod groups

The members of subpods almost always (>95%) travelled together. However, the members of some subpods travelled in discrete and very cohesive groups that we have termed intra-pod groups. An individual only very rarely separated from its intra-pod group for more than a few hours. These groups were named after one of their members. Subpods contained 1–11 (mean=1.9) intra-pod groups and intra-pod groups contained 2–9 (mean=3.6) individuals. The term intra-pod group will be replaced later in the report by the term 'matrilineal group' (see Section 4.1.4).

In almost all cases (50 of 52), the members of each intra-pod group linked in clusters at $\geq 15\%$ CAI in the dendrograms which conformed with intra-pod memberships determined by direct observation. However, direct observations indicated that two adult males were linked to the wrong intra-pod groups. One male (K02) was linked to intra-pod K08 when direct observations indicated it was a member of intra-pod group K01. This error resulted from the small number of photographs taken of K02 which died within a year of being identified. Another male (R01) was placed in group R14 when direct observations indicated that it was a member of group R09. This error probably resulted because adult males occasionally travelled with other unrelated adult males, and intra-pod R14 consisted of two adult males. To prevent these two misplacements from distorting subsequent linkages, we utilized an interactive version of the single-link algorithm that allowed us to reject linkages. Both males were placed in their proper intra-pod groups as a second choice.

The six individuals (A16, A17, A18, C11, C15, J24) that died or were cropped prior to the start of the study were excluded from the association analysis as were four calves (A41, B13, G41, G42) for which there were few photographs. The identity of the intra-pod groups for these individuals was established solely on the basis of direct observations.

The southern community comprised 25 intra-pod groups and the northern community 37 intra-pod groups (Figs 4–5 and Appendix Figs A–T). With the exception of pod L01, pods were made up of 1–5 (mean=2.6) intra-pod groups and subpods 1–4 (mean=1.6) intra-pod groups. Pod L01's three subpods were comprised of 15 intra-pod groups, one sub-pod of which contained 11 intra-pod groups.

4. GENEALOGY

4.1 Genealogies within pods

We established the genealogies among individuals within pods based on the offspring with known mothers and, for other offspring, the relative strength and continuity of their bonds with potential mothers. As will be shown below, the bond between an offspring and its mother lasts for many years and is stronger than that with any other potential mother.

Maternal genealogical trees were constructed cumulatively from the youngest to the oldest offspring. The process involved three basic steps. First, the offspring that were to be incorporated into the tree were selected

beginning with those born during the study, followed by those that were juvenile at the start and finally by those that were mature at the start of the study. Second, the potential mothers of the offspring were identified. All mature females in the offspring's pod were considered as candidates providing that they could have been at least 15 years (mean age of maturity) older than the offspring. However, an offspring's own mature daughters were excluded as potential mothers. We also excluded females that matured during the study after a particular offspring was born so as to ensure that young adult sisters would not be potential mothers. Third, the relative strength of bonds between offspring and all potential mothers were examined. The potential mother with which the offspring was most closely bonded was assumed to be its mother (Section 4.1.2).

The CAI values for all years pooled were arranged into matrices to facilitate comparisons (Figs 6–7; Appendix Figs A–T). One matrix was constructed for each pod, except for pod L01 which was too large to place conveniently in one matrix. Pod L01 was divided into its L10, L35 and L08 subpods. Due to its size, subpod L08 was further divided into: (1) intra-pod groups L07, L08, L21, L25, L26 and L37; and (2) intra-pod groups L02, L03, L04, L09 and L27. Although the splitting of subpod L08 was somewhat artificial, individuals within each set of intra-pod groups generally had higher associations with one another and each set formed a distinct cluster in the association dendrogram (Fig. 4). The 10 individuals (A16, A17, A18,

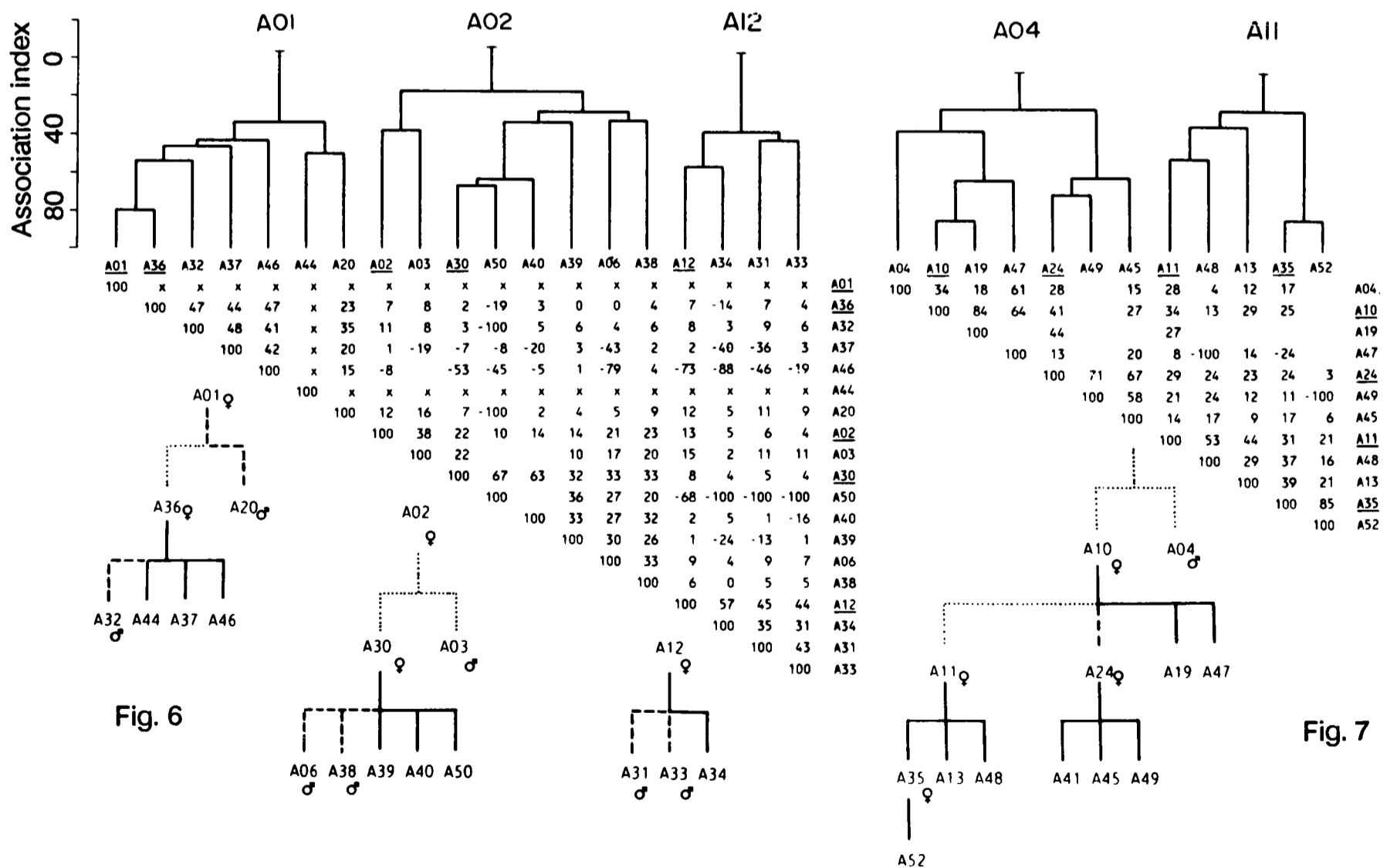

Figs 6 and 7. Genealogy of pod A01 (Fig. 6) and pod A04 (Fig. 7). Cole's association index (CAI) dendrograms showing intra-pod groups (top); matrix of CAI values (middle) and genealogical trees (bottom) based on data for all years pooled. The alpha-numeric codes above each intra-pod group represents their names and the height of the bar the level at which the group links to another intra-pod group. All adult females are matrices. Solid lines in the genealogical trees denote positive genealogies, dashed lines highly probable genealogies and dotted lines probable positioned to the left.

C11, C15, J24, A41, B13, G41, G42) that were excluded from the CAI dendrograms were also excluded from the matrices. Six additional individuals (A01, A21, A44, B11, I10, K02) were excluded from the matrices because of photographic bias during 1973–75 (Section 2.5.2) or because there were too few photographs of them. The relative strength of bonds for these 16 whales was assessed solely on the basis of direct observations.

Genealogical assignments were classified into three levels of certainty based on the relative age of the offspring and the likelihood of error in assigning a mother to an offspring: (a) positive genealogies for offspring born during the study and for which the mothers were known (Section 2.3); (b) highly probable genealogies for offspring that were juvenile at the start of the study; and (c) probable genealogies for offspring that were mature at the start of the study.

Identifying the mothers of offspring at the positive and highly probable levels of certainty was usually straightforward, but identifying the mothers of offspring at the probable level was more complex. Although mature offspring exhibited stronger bonds with their mother than with any other potential mother, the bonds were often subtle and varied with time. For example, the bond between a daughter that matured early in the study and her mother generally weakened during the study when the daughter gave birth to her own calves. Similarly, the bond between an adult female and other members of the pod generally weakened when her son matured, because adult males tended to make her intra-pod group more independent (Section 4.1.4). Temporal variations in bond strength were taken into account in direct observations by reassessing bonds each year and in the association analysis by examining the CAI values within the four year-groups. Mother-offspring assignments were also checked for consistency with other lineages in the genealogical trees. Thus, an offspring had to have a sufficiently strong bond with not only its mother, but also with its siblings. Similarly, cross-checking of bonds within matrices was undertaken to ensure that offspring had higher CAI values with their mothers than other potential mothers and that the mother also had high CAI values with the offspring compared to all potential offspring.

An offspring not strongly bonded to any potential mother was not assigned a mother because the mother may have died or been live-captured prior to the start of the study. In some cases, subtle bonds existed between an offspring and its suspected mother, but if the bond was not clearly stronger than with the other potential mothers then the mother was not assigned. Thus, the mothers for some offspring, particularly adult females, were probably not identified. In general, both direct observations and the association analysis indicated the same genealogies. The few discrepancies that existed between the two methods are noted and discussed.

4.1.1 Genealogical trees within pods A01 and A04 – two examples

Pods A01 and A04 were selected to illustrate the procedure used to construct genealogical trees. These pods were chosen for several reasons: (1) the pods were observed and photographed extensively during 1973–87; (2) neither pod was known to have been cropped; and (3) several approaches were required to assign mothers to offspring.

(a) POSITIVE GENEALOGIES

The mothers of the 16 offspring born in these pods during the study were considered to be known based on direct observations (Section 2.3). In pod A01 (Fig. 6), A36 was the mother of A44, A37 and A46; A30 was the mother of A39, A40 and A50; and A12 was the mother of A34. In pod A04 (Fig. 7), A24 was the mother of A41, A45 and A49; A10 was the mother of A19 and A47; A11 was the mother of A35, A13 and A48; and A35 was the mother of A52. Note that A35 was both a daughter and a mother.

The above genealogical assignments were also supported by the association analysis. The known mothers for 14 offspring were also the potential mothers with which the offspring had their highest CAI values. The two exceptions were the offspring that were excluded from the association analyses. A41 was excluded from both the dendrogram and matrix because it had been photographed only a few times and A44 was excluded from the matrix because of photographic bias.

(b) HIGHLY PROBABLE GENEALOGIES

At the start of the study, pod A01 contained juveniles A06, A20, A32, A38, A31 and A33; and pod A04 contained juvenile A24. Direct observations indicated that the mother of A20 was A01; the mother of A32 was A36; the mother of A06 and A38 was A30; the mother of A31 and A33 was A12; and the mother of A24 was A10. To assign mothers to these offspring by association analysis, we assumed that the real mother was the potential mother with which it had its highest CAI value. The association analysis also indicated that these offspring had the same mothers as determined by direct observations. The only exception was A20, which had its highest CAI with its sister A36. The latter discrepancy resulted because A20's mother, A01, had been excluded from the matrices because of photographic bias.

(c) PROBABLE GENEALOGIES

At the start of the study, pod A01 contained adult females A01, A02, A12, A30, A36 and adult male A03, and pod A04 contained adult females A10 and A11 and adult male A04. An important consideration in assigning genealogies at this level was the relative ages of the adult females. For example, females A01 and A02 were likely to be the oldest because they appeared to be post-reproductive (Section 2.4.2) at the start of the study. Adult female A12 was also likely to be among the oldest because she appeared to become post-reproductive early in the study. Female A11 was likely to be the youngest. Although she was adult-size when first seen in 1973, she had no offspring travelling with her, but subsequently gave birth to three calves between 1974 and 1983 and thus appeared to have matured early in the study. Females A10, A30 and A36 were likely to be older than A11 because they had juvenile offspring travelling with them when the study began and continued to calve during the study.

In pod A01, direct observations indicated that A36 and A01 were strongly bonded as were A30 and A02. When relative ages were taken into account, A36 was assigned as the daughter of A01 and A30 as the daughter of A02. The latter assignment was supported by the association analysis which indicated that A30 exhibited a higher CAI value with A02 than with any other potential mother. The assignment of A36 as the daughter of A01 could not be confirmed by the association analysis because A01 was excluded from the CAI matrix. Both direct observations

and CAI values indicated that A12 was not strongly bonded to any potential mother, which suggests that its mother died prior to the start of the study.

Both direct observations and CAI values indicated that the adult male A03 was likely to be the son of A02. Note that the CAI value of the son (A03) with his mother (A02) was higher than that of his sister (A30) and her mother, which was typical for adult sons and adult daughters (Section 4.1.3). In addition, adult males typically had much weaker bonds with their adult sisters than their mothers. This characteristic weaker bond between an adult brother and his adult sister was useful for assigning an adult male as a brother rather than a son in cases where the mother had died prior to the study but his sister remained alive.

In pod A04, direct observations indicated that A11 and A10 were strongly bonded. When relative ages were taken into account, A10 was assigned the mother of A11. This assignment was supported by the high CAI value of A11 with A10. The adult male A04 was probably the brother of A10. He was too old to be the son of either A11 or A24. While his association was slightly higher with A10 than with A11 and A24, it was not high enough to be the son of A10. In addition, when cross-checking was undertaken of the importance of bonds for A04 and A10, it was apparent that A10 did not have the characteristic stronger bond with A04 than with her daughters A11 and A24.

4.1.2 Genealogical trees within all pods

In this section, we construct genealogical trees for all pods in the same manner as for pods A01 and A04 (Appendix Figs A-T). We also show that offspring have a stronger bond with their mother than with any other potential mother, and that this strong bond lasts throughout the mother's lifespan. The evidence for life-long bonding comes from an examination of relative bond strength and the continuity of bonds (1) between offspring and known mothers in the positive category of genealogy and (2) between offspring and potential mothers in the highly probable and probable genealogical categories.

(a) POSITIVE GENEALOGIES

The mothers of the 133 offspring born during the study were known from direct observations. Of the 127 offspring that could be examined by association analysis, all had higher CAI values with their known mother than with any

other potential mothers in their pod. The mothers of four offspring could not be confirmed because the offspring were excluded from the matrices and the mother of one could not be confirmed because the mother was excluded from its matrix.

Direct observations indicated that as offspring aged during the study they maintained their strongest bonds with their known mother. The continuity of the mother-offspring bond was also evident from the high proportion of cases (232 of 238 cases) in which the CAI with the known mother ranked the highest of all potential mothers in the four data year-groups (Table 2). Of the six exceptions, five offspring had their highest CAI values with their grandmother and their second highest with their mother. These exceptions probably occurred by chance due to the small sample sizes in the year-groups. This was indicated by the fact that no exceptions existed for the large sample sizes in all years pooled, 1973–87. Also, the bonding between an offspring and its grandmother is often only slightly less than with its mother because an offspring travels closely with its mother which in turn travels closely with its own mother. At the end of the study, offspring in the positive genealogical category ranged in age from 0.5 to 14.5 years (mean=5.7 years) and five had matured. Thus, the offspring of both sexes maintain strong bonds with their mothers from birth into adolescence and early adulthood.

(b) HIGHLY PROBABLE GENEALOGIES

There was a high probability that the potential mother with which a juvenile was most strongly bonded at the start of the study was also its real mother. The reason is that offspring that were juvenile at the start of the study were of similar ages to those in the positive category at the end of the study; and the latter offspring were still most strongly bonded to their known mothers. The estimated ages (Section 2.4.2) of juveniles in the highly probable category at the start of the study ranged from 1.5 to 20.5 years (mean=8.3 years).

The mothers of 80 juveniles were identified using direct observations. Seventy-seven (96.3%) of the mother assignments were supported by the association analysis. Three juveniles had slightly higher CAI values with a potential mother other than its mother identified by direct observations. Two of these juveniles (L38, L42) had their highest CAI values with their grandmothers and second

Table 2

Continuity of mother-offspring bonds within the year-groups 1973-76, 1977-80, 1981-84 and 1985-87. The CAI values between offspring with their assigned mothers were ranked relative to those between offspring and all other potential mothers in the first and each subsequent year-group an offspring was photographed. Mother-offspring pairs assigned solely on the basis of CAI values were omitted (i.e. all others included direct observations, as were year-groups in which either an offspring or its mother appeared in fewer than 10 photographs. Numbers in parentheses indicate percentages.

Genealogical Category	Rank of CAI	1st year group	2nd year group	3rd year group	4th year group	All year-groups	1973-87 pooled
Positive	1	126 (99.2)	64 (97.0)	31 (91.2)	11 (100.0)	232 (97.5)	127 (100.0)
	2	1 (0.8)	1 (1.5)	3 (8.8)	0 (0.0)	5 (2.1)	0 (0.0)
	±3	0 (0.0)	1 (1.5)	0 (0.0)	0 (0.0)	1 (0.4)	0 (0.0)
Highly Probable	1	77 (97.5)	59 (96.7)	55 (90.2)	38 (92.7)	229 (94.6)	75 (94.9)
	2	2 (2.5)	1 (1.6)	3 (4.9)	2 (4.9)	8 (3.3)	4 (5.1)
	±3	0 (0.0)	1 (1.6)	3 (4.9)	1 (2.4)	5 (2.1)	0 (0.0)
Probable	1	26 (96.3)	22 (88.0)	23 (100.0)	15 (100.0)	86 (95.6)	27 (100.0)
	2	0 (0.0)	0 (0.0)	0 (0.0)	0 (0.0)	0 (0.0)	0 (0.0)
	±3	1 (3.7)	3 (12.0)	0 (0.0)	0 (0.0)	4 (4.4)	0 (0.0)

highest with their mothers; and one (R04) had a higher value with an adult female of unknown relatedness and second highest with its mother. Based solely on the association analysis, two males (L10, K01) were assigned mothers and a third male (J06) was identified as the brother of a female that had no living mother during the study. The latter three bonds were not apparent from direct observations.

The strong bond that existed between each offspring and its highly probable mother was maintained as the juveniles grew older during the study. Direct observations indicated that offspring of both sexes maintained their strong bonds with the highly probable mother throughout the study. As in the positive category, support for this observation was evident from the high proportion of cases (97.5%) where the CAI with the highly probable mother ranked higher than any other potential mother (Table 2). Of the 13 (2.5%) cases in which the mother did not rank the highest, the mother was second to the grandmother in eight. As noted earlier, such errors were to be expected occasionally by chance. By the end of the study, offspring in this category ranged in age from 13.5 to 34.5 (mean=19.7) years. Thus, the strong mother-offspring bond was maintained well into adulthood.

A potential source of error for genealogical assignments in the highly probable category was that the real mother had died prior to the start of the study. In such cases, a juvenile might bond with another adult female. One case was recorded in which this error would have taken place had the study begun later. In this case, the lineage consisted of a grandmother (L25), her daughter (L23) and her grandson (L14). Following the daughter's death in 1982, the grandson travelled mainly with his grandmother, which would then have been mistaken as its mother. However, the frequency of this type of error was probably small because reproductive females had extremely low mortality rates. Based on the mortality rates given in Olesiuk and Bigg (1990), we estimated that 96% of mothers would still be living 8.3 years after they gave birth (i.e. the mean age of juveniles in the highly probable genealogical category at the start of the study). The potential for this error was greater in cropped than uncropped pods, but was probably still small. Most juveniles born to females that were cropped were likely to have been cropped themselves because of the strong mother-offspring bond and the fact that whales were often cropped in groups. Moreover, relatively few adult females were cropped. Of the resident whales removed, 83% were juveniles or mature males (Olesiuk and Bigg, 1990).

(c) PROBABLE GENEALOGIES

The preceding category suggests that adult offspring that had living mothers at the start of the study would still be more strongly bonded with their mothers than with any other potential mother. However, there was a higher probability that the mother of offspring in this category died prior to the start of the study. The likelihood that the mother died prior to the study would be largely a function of the age of the adult offspring, which ranged from about 10 years to at least 40–50 years at the start of the study.

The probable mothers were identified for 34 of the 102 individuals that were adult at the start of the study. The mothers of 24 of these offspring were based on direct observations and were supported by the association analysis. Based on the CAI values, we placed an additional 10 adult offspring to lineages that were not apparent from direct observations. These offspring included one male

(C01) and three females (K11, L07, R07) that were assigned to living mothers, as well as four males (G01, G07, J01, L16) and two females (L26, L37) that did not appear to have living mothers, but were assigned as siblings of living females.

As with the highly probable genealogical category, direct observations indicated that the bond an offspring had with its probable mother established at the start of the study was maintained throughout the study. This finding was supported by the consistently high ranking of CAI values with the probable mother compared to all potential mothers (Table 2). Thus, evidence from the three levels of genealogical certainty suggests that the offspring of both sexes remained bonded to the mother throughout the mother's life.

A possible source of error in the lineages at the probable level of certainty was that young infertile adult females may have been mistakenly classified as old post-reproductive females, in which case the females classified as grandmothers (e.g. A07, G30, L28) would have been daughters. However, the potential for this error was small because infertile females appear to be rare. With one exception (K40), all females that were large juveniles at the start of the study gave birth during the study. Conversely, reproductive senescence appeared to be much more common than infertility because many older females became post-reproductive just prior to or during the study (Olesiuk and Bigg, 1990).

4.1.3 Sex- and age-specific mother-offspring bonds

The change in strength of the mother-offspring bond with age was examined using CAI values for the year-groups 1973–76, 1977–80, 1981–84 and 1985–87. The mean CAI values (\pm SE) were plotted as a function of the estimated age of the offspring at the midpoint of each year-group (Fig. 8). It should be noted that the estimated ages were minimum ages, especially those of adults (Appendix Tables A-B). However, the bias introduced by using minimum ages for adults was likely to be small because changes in the strength of bonds were asymptotic with age.

The bond between a mother and her daughter declined with age until the daughter reached her late teens or early twenties at which time the bond stabilized at a CAI of

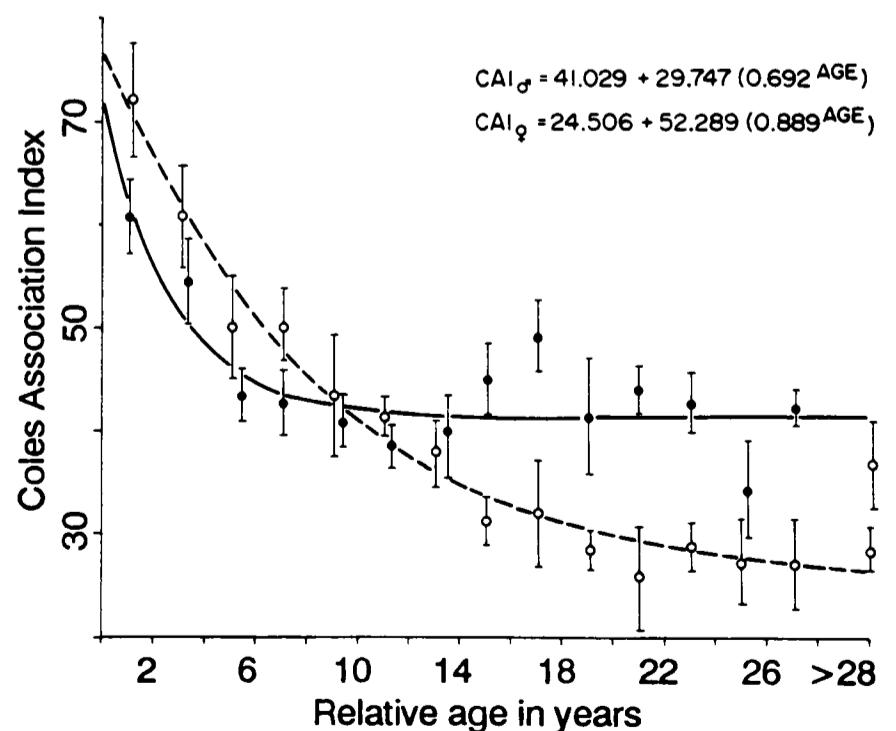

Fig. 8. Changes in mean (\pm SE) Cole's association index (CAI) between male (●) and female (○) offspring and their mothers as a function of the offspring's estimated age at the midpoint of each year-group. All offspring of known sex were included (n=124).

about 25. The decline with age may be more pronounced than indicated because adult females that were weakly bonded with their mothers may not have been identified as daughters (Section 4.1.4).

The bond between a mother and her son initially declined more rapidly with age than with her daughter, but stabilized by about 10 years of age at a CAI of about 40. Thus, young sons tended to spend more time away from their mothers than did young daughters. However, adult sons remained more closely bonded to their mothers than did adult daughters. Direct observations suggest that the reason for this is that adult daughters travelled closer to their progeny than do their own mothers.

4.1.4 Interpretation of genealogical trees

An examination of the genealogical trees for the intra-pod groups indicated that these groups were matrilineal groups comprising mothers and their descendants. Intra-pod groups are therefore subsequently referred to as matrilineal groups, a term which more appropriately conveys the significance of the group.

Matrilineal groups were made up of 1–4 (mean=2.3) generations, although 2–3 generation groups were the most common. Only one group (R14) was only a single generation and it consisted of two adult males that were probably brothers whose mother had died prior to the study. Three matrilineal groups (J01, K01 and L28) were made up of four generations. In each case the 4th generation was born late in the study (1986–87). Several other matrilineal groups nearly attained four generations. For example, the two first generation members of matrilineal group A04 died 3–4 years prior to the birth of the fourth generation calf. A generalized matrilineal group was comprised of a grandmother, her adult son and adult daughter and the offspring of her daughter.

Only two individuals could not be fitted into the matrilineal groups indicated by their dendrograms. The adult male I10 was placed in group I11, but few data existed for this individual because it died early in the study before many photographs could be taken of its pod. An examination of photographs with more than one individual present indicated that he did not belong clearly to either of the two groups in his pod (Appendix Fig. L). Perhaps the two oldest females in the two matrilineal groups of its pod were his sisters. The other exception was adult female R17 and her offspring. She was placed into group R05 in the dendrogram, but could not be fitted easily into the genealogical tree (Appendix Fig. H). She appeared to be an adult at the start of the study, and had she not given birth late in the study, she would have been considered a post-reproductive female and the mother of R05. However, with the birth of her calf she appeared to be too young to be both a young reproductive female and the mother of R05. Perhaps she was an unusually old reproductive female and the mother of R05.

Some matrilineal groups were linked into extended matrilines. A few were linked by a common mother that was alive during the study (e.g. A04 and A11; J05 and J10; L07 and L37; R04 and R18; D07 and D08). Other groups were linked because the adult female in one was thought to be the mother of an adult female in another (e.g. L04 and L27; A08 and A09; I02 and I22). In a few cases, groups were linked through a common mother that was thought to have died prior to the study (e.g. L07, L26 and L37). Other

linkages between matrilineal groups were likely to have been missed. Sometimes the relative ages of females in two groups were not known precisely enough to be sure which was the potential mother (e.g. groups I17 and I18; G08 and G12). In addition, the bond between two adult sisters was often not strong after their mother died and thus the genealogical relationship between sisters would be missed if the mother died prior to the study.

Another difficulty in linking matrilineal groups was that the bonds sometimes varied with time depending on the presence of adult males in the group. Direct observations indicated that the presence of adult males appeared to make a matrilineal group more independent from other groups within its pod. This was also evident in the dendrograms for groups with at least one adult male, such as K30, L15, L35, A12, G04 and R14, all of which were relatively weakly bonded with other groups in their pod (Figs 4–5).

An example of the sometimes complex travel association that existed among matrilineal groups is illustrated by groups A05 and A08, which we believe were related by way of a mother and her daughter. The dendrogram (Fig. 5) indicated that matrilineal group A08 associated mainly with group A14, rather than its mother's group, A05. The oldest females in groups A08 and A14 were not likely related through mother and daughter because they were of similar ages. Group A09 sometimes left its pod to travel alone or with another pod because the group had two adult sons (A05, A26) that tended to make it more independent. This left the daughter group A08 to travel with other groups in the pod, in this case mainly group A14. When group A09 returned to its pod, group A08 travelled mainly with it suggesting the lineage. On occasions when group A09 left the pod with another group, it invariably did so with group A05, which also indicated close relatedness.

Matrilineal groups appear to have three possible fates. One is for them to die out, as was the case for matrilineal groups K30 and L15 which contained only post-reproductive females and their adult sons (Appendix Figs B-C; and Appendix Table A). This will also likely be the fate of groups G04 and R02 which also comprised post-reproductive females and their adult sons. Alternatively, matrilineal groups may perpetuate themselves for many years by producing a single adult daughter in each generation, as was the case for groups J02 and K07. Third, matrilineal groups may increase in size and divide when several daughters are raised to adulthood, as was the case for groups I18, G12, D07, A10, J09 and L09. We witnessed the formation of two new matrilineal groups during the study. They formed by the gradual splitting of an existing matrilineal group along maternal lines. Each new group formed following the death of the common mother (e.g. A10 and J09) that linked a pair of adult daughters (A24 and A11; J05 and J10); one daughter from each group then formed a new group.

The fate of a matrilineal group depends not only on its sex and age composition, but also on the status of the entire population. In an increasing population, the majority of groups would be growing and dividing, whereas in a decreasing population, the majority of groups would be dying out. A population assessment indicated that both the northern and, prior to capping, the southern communities had been increasing in size since at least 1955 (Olesiuk and Bigg, 1990). Thus, the majority of matrilineal groups were likely to have been increasing in size and dividing during the past few decades.

Following division, matrilineal groups are likely to remain bonded together because no dispersal of matrilineal groups was recorded. Thus, the matrilineal groups within a subpod are probably closely related.

New subpods and ultimately pods probably also form by fission. Thus, the three alternate fates described for matrilineal groups, of dying out, remaining stable or growing, probably exist for subpods and pods. However, the process probably occurs on a much longer time frame than for matrilineal groups. Fission within matrilineal groups can take place within one generation (2–3 decades). The formation of new subpods would take longer, probably many decades and new pods would likely take many decades or even centuries. Pods and subpods that consist of only one matrilineal group (e.g. pods B01, I31, H01, I01; subpod L35) might be the remnants of a group that is dying out or the descendants of a group that is stable over several generations. Pod W01 will likely die out because it contains only a post-reproductive female and her adult sons.

Subpods that grow in size are likely to form new pods. The three subpods in pod A01 and the two subpods in each of the pods A04, C01 and D01 appeared to have spent increasing periods of time apart from one another during the study and thus may be in the process of becoming new pods. As is discussed in Section 4.2, recently formed pods appear to associate with one another, whereas pods showing distant ancestors associate randomly.

4.1.5 Swimming formation

Direct observations indicated that individuals within matrilineal groups usually swam in formations that correlated largely with genealogy. A mother usually surfaced with her offspring clustered beside and slightly behind her (Fig. 9). Thus, matrilineal groups are typically matrifocal in that all other individuals in the group cluster around the adult females. Matrilineal groups contain 0–3 (mean=1.3) adult females. Young juveniles travelled closest to their mothers. Adult sons generally swam next closest, either beside or slightly behind their mothers. Adult daughters were positioned slightly farther from the mother and were in turn followed by their offspring. Siblings usually travelled closely with one another because they all travelled close to their common mothers. An adult male with no living mother, but with a living adult sister, tended to travel on the periphery of her group.

The distance separating whales in a matrilineal group depended on the activity of the group. Offspring generally stayed within 1–3m of their mother when resting. They were more loosely clustered when travelling or feeding, but usually remained within 10–20m of their mother and seldom ventured more than 100m away. Even when the group was widely dispersed, the offspring were still the individuals travelling closest to their mothers. Bonds weakened among all group members when the pod began to play or when other pods joined and socialized. During these times offspring sometimes travelled with adult females other than their mother or with non-siblings. Unrelated mothers occasionally preferred to travel more closely with each other (e.g. A09 and R09) than with their own offspring. However, individuals usually re-assembled into their own matrilineal group within a few hours.

4.2 Genealogies among pods

Two approaches were used to examine genealogies among pods. First, we determined the degree of association among pods based on the relative strength of bonds among individuals within each community (Fig. 10). Pods G01 and G12 associated quite strongly as did pods I01, I02 and I18, which suggested these pods might be more closely related to one another than to other pods. However, the associations among other pods were weak, which suggested that they travelled almost randomly with one another.

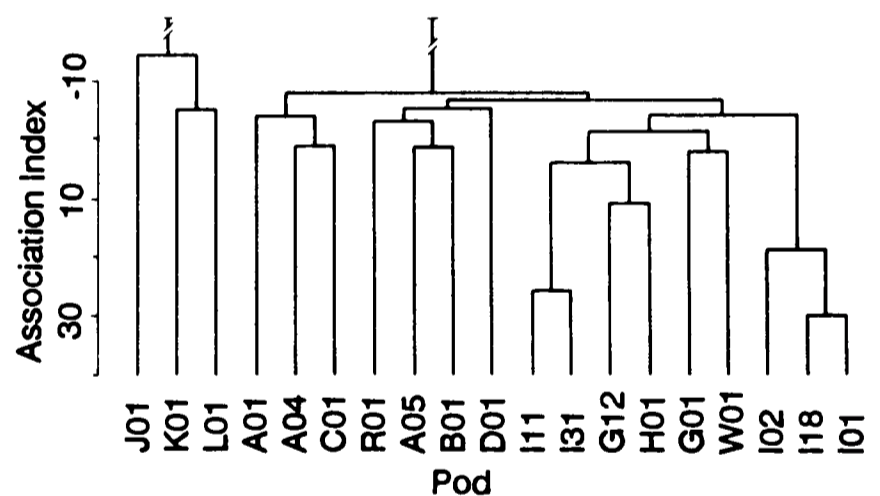

Fig. 10. Dendrogram showing associations of pods in the southern and northern communities (summarized from Figs 4–5).

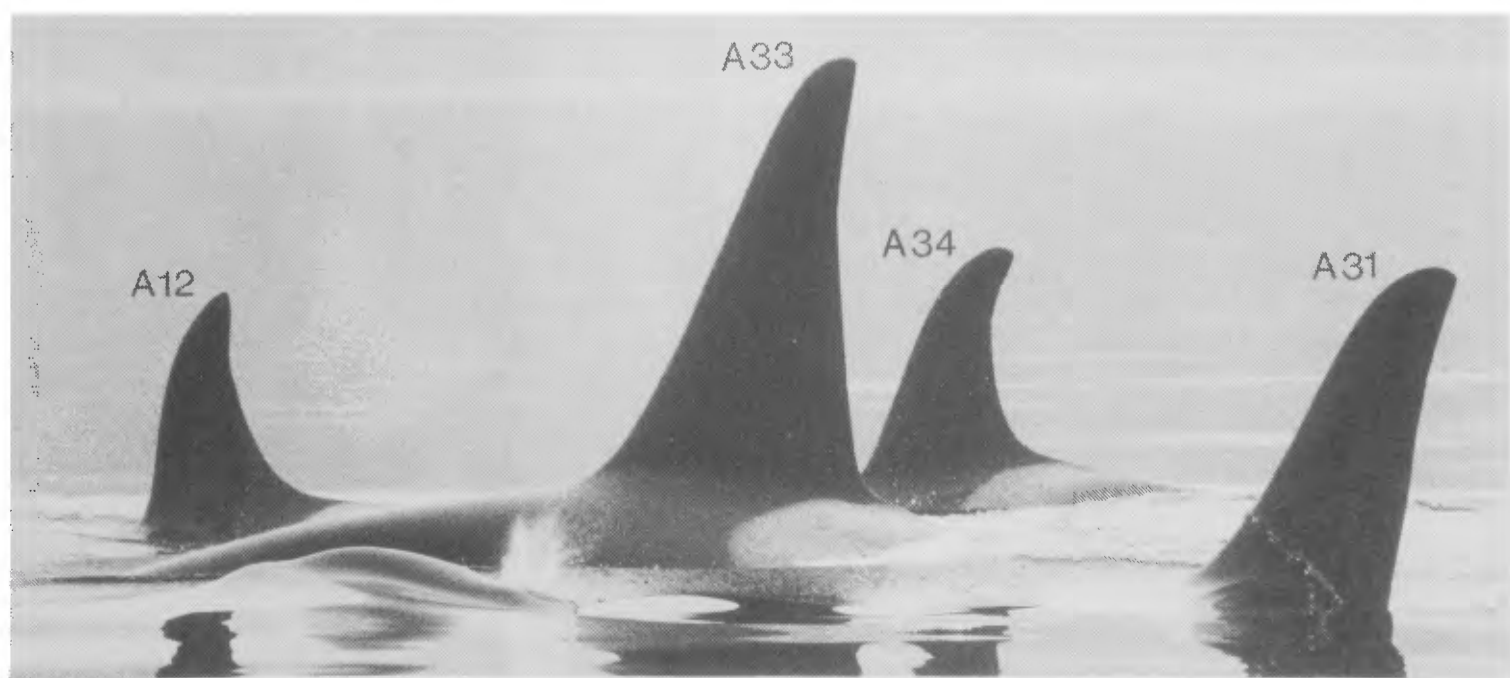

Fig. 9. Typical swimming formation of the members of a matrilineal (intra-pod) group. Matrilineal group A12 is shown with mother A12 followed by her two adult sons, A31 and A33, and juvenile daughter A34. Photo: J. Ford, 12 August 1988.

Second, we examined pod genealogy based on pod-specific dialects. Ford and Fisher (1982; 1983) and Ford (1984) found that resident killer whales in this region made three types of vocalizations, one of which was 'discrete calls'. The discrete calls within pods were stable with time (> 25 years), but varied between pods. Pods that shared discrete calls were considered to belong to the same acoustic 'clan', whereas pods that shared no calls were considered to belong to different clans. Within a clan, each pod produced unique calls or structural variations of calls. In view of the stability of discrete calls with time, Ford (1984) argued that pods within each clan shared a common ancestor and that the degree of similarity of calls among pods within a clan indicated a measure of their genealogical relationship. Pods with similar call repertoires were likely to be more closely related than those with dissimilar repertoires.

The acoustic similarity of pods is shown in Fig. 11, which is Ford's (1984) original Fig. 48 modified to account for the revision of G pod into pods G01 and G12 and of I1 pod into pods I01, I02 and I18 (Section 3.2). The dialects of the revised pods were essentially the same as in the original pods. Thus, Ford's (1984) conclusion that the northern community comprised three acoustic clans remains valid.

A comparison of Figs 10 and 11 indicates that few similarities exist between travel bonds and call repertoires. Both methods suggest that pods G01 and G12 are closely related as are pods I01, I02 and I18. However, in many cases pods tend to associate more strongly with pods outside their acoustic clan than within. For example, the two pods in R Clan (R01 and W01) are acoustically very similar, yet show no tendency to travel together.

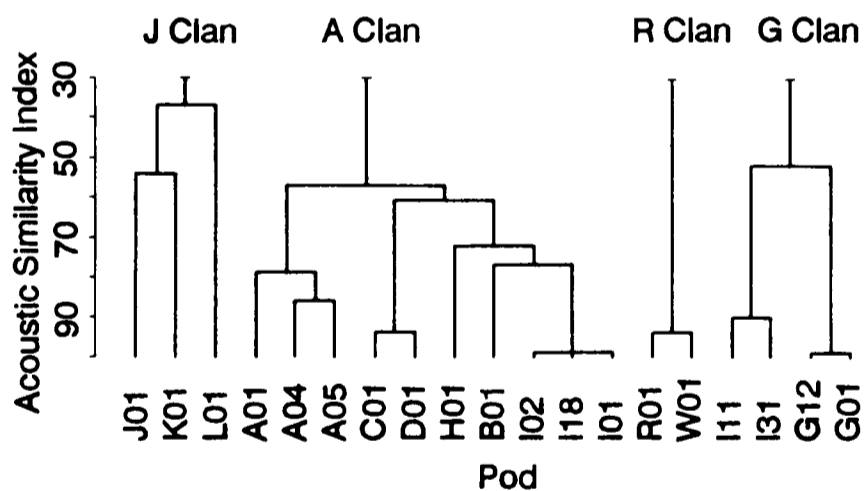

Fig. 11. Acoustic similarity of pods in the southern and northern communities (up-dated version of Fig. 48 in Ford, 1984).

Dialects probably indicate pod genealogies more accurately than do travel associations. The differences in pod-specific dialects are much more distinctive than travel associations. Moreover, discrete calls appear to be more stable than the bonds among individuals related by a common recent ancestor. For example, the presence of adult males tends to make pods more independent as was the case for matrilineal groups. The most independent pod was pod B01, in which six of its 11 members were adult males at some point during the study (Fig. 5). Pod W01 also had a high proportion (50%) of adult males and was nearly as independent.

We conclude that the strength of travel bonds provides a useful index of genealogies for individuals within pods, but is of limited value at the pod level. On the other hand, dialects do not indicate genealogies within pods, but are

useful for identifying pods and for determining genealogies among pods. Thus, acoustic clans are not social units, but rather groupings of pods based only on a common lineage.

5. DISCUSSION

Other studies have reported groups within pods in the northern and southern communities. Jacobsen (1986) observed A01, A04 and A05 pods in Johnstone Strait during 1979–84 and concluded that they comprised maternal groups. Although he did not specify the membership of the groups, they coincided with our matrilineal groups (J. Jacobsen, Humboldt State University, California, pers. comm.). S.L. Heimlich-Boran (1986) observed pod J01 in Haro Strait during 1976–80. The four groups identified in her Fig. 11.10 were the same as our matrilineal groups. Although not yet published, other researchers studying the northern community since the early to mid-1980s have confirmed the membership of pods and their matrilineal groups in pods A01, A04, A05, B01, C01, D01, G12, H01, I02, I11, I31 and W01 and to some extent in pods G01, I01, I18 and R01 (D. Bain, J. Waite, N. Rose, University of California, Santa Cruz; A. Morton, Simoon Sound, British Columbia; J. Jacobson; pers. comm.). Similarly, R. Hoelzel (Cambridge University, England; pers. comm.) examined and confirmed the pods and their matrilineal groups in the three pods (J01, K01 and L01) of the southern community.

No instances of individuals moving between pods have been documented in the literature, but, contrary to our findings, two instances of matrilineal groups moving between pods have been reported. However, an examination of these cases indicated that neither had actually occurred. In the first case, Osborne (1986) stated that matrilineal group K18 (formerly matrilineal group L18) moved permanently from pod L01 to pod K01. In fact, group K18 was always part of pod K01 and we had erred in originally assigning it to be as part of pod L01. When Osborne (1986) observed the group with pod K01, he assumed that it had changed pods. In the second case, Jacobson (1986) reported that matrilineal group C05 (J. Jacobsen, pers. comm.) in pod C01 travelled more frequently with pods A01, A04 and A05 during his study. However, more recent data indicated that, while it still travelled the majority of time with pod C01, it may be in the process of becoming a new pod.

Both Jacobsen (1986) and S.L. Heimlich-Boran (1986) concluded, as we have, that the bonds between offspring and their mothers persisted for many years. Similarly, Morton (1985) observed pods A01, A04 and A05 in the mainland inlets off northeastern Vancouver Island during 1982–85 and noted that individuals travelled in groups of one or two adult females and their offspring. S.L. Heimlich-Boran (1986) commented that pod J01 contained non-reproductive adult females (e.g. J02, J08 and J09) and was uncertain as to their role. Haenel (1986) argued that these females provided allomaternal care. However, our studies indicated that such females were post-reproductive and probably the mothers of the reproductive females in the matrilineal group.

The results of our study indicate that resident killer whales travel in kinship groups and that these groups form the basis of progressively larger social groupings (Table 3). Other mammals, such as canids and primates, have also been reported to travel in kinship groups of siblings and parents (Chepko-Sade and Sade, 1979; McDonald, 1983;

Table 3

Summary of social organization and genealogy of resident killer whales in the study area. No dispersal occurred at any level of organization.

Unit	Composition	Definition	Genealogy
Matrilineal (intra-pod) group	2-9 (mean=3.6) individuals of mixed age and sex	Group of individuals that always travel together and in close proximity to one another (Section 3.4). The groups are matrilineal (Section 4.1.5).	Matriline of 1-4 (mean=2.7) generations (Section 4.1.4).
Subpod	1-11 (mean=1.9) matrilineal groups	Matrilineal group(s) that almost always (>95% of the time) travel with one another (Section 3.3).	Closely related matrilines (Section 4.1.4); matrilines within subpods are more closely related to one another (e.g. share a common mother) than to matrilines in other subpods and matrilines within pods more closely related to one another than to matrilines in other pods.
Pod	1-3 (mean=1.7) subpods	Subpod(s) that travel with one another the majority of the time (Section 3.2). Dialects are pod-specific (Section 4.2).	
Clan	2-10 (mean=4.8) pods	An acoustic grouping of pods that share one or more discrete calls. Most pods exhibit little preference for travelling with other pods within their clan (Section 4.2). Not a social group.	Pods that share a common distant ancestor (Section 4.2). Pods within clans with very similar dialects and which tend to travel together are likely most closely related whereas those with dissimilar dialects are likely most distantly related.
Community	1-3 (mean=2.0) clans	Pods that associate with one another (Section 3.1).	Closed populations.

Trivers, 1985). Individuals that travel in such groups are thought to gain indirect fitness through cooperation with relatives.

Studies of other social species (e.g. Kurland, 1977) have shown that bonds among individuals within matrilineal groups correlate with the degree of relatedness. The degree of relatedness is the proportion of genes shared by any two individuals such that an offspring is more related to its mother than its grandmother (Trivers, 1985). If siblings have different fathers, as is suggested for killer whales from an examination of relative testes sizes (Landino, 1985), then an offspring would be related less to siblings than to its mother and less to cousins and so on. Thus, the relative strength of bonds among individuals within pods of killer whales appeared to be correlated with degree of relatedness.

The absence of emigration and immigration from the natal groups of resident killer whales appears to be unique among mammalian social systems. In all other species, to our knowledge, offspring of one or both sexes leave their natal groups by the time they mature. Dispersal has been documented extensively in the social systems of terrestrial mammals (Greenwood, 1980) and of pinnipeds (Ridgway and Harrison, 1981a; 1981b). For cetaceans, baleen whales generally do not form cohesive groups like odontocetes, although they may form large assemblages for feeding (Norris and Dohl, 1980). Dispersal was found in the few odontocetes that have been examined for this feature (e.g. humpbacked dolphin, bottlenosed dolphin, Hawaiian spinner dolphin, sperm whale; see Norris and Dohl, 1980; Wells, Irving and Scott, 1980). However, dispersal has not been examined for the pilot whale (*Globicephala* spp.) and false killer whale (*Pseudorca crassidens*) which have social systems that appear to be similar to that of killer whales. Kasuya and Marsh (1984) speculated that bonds between female short-finned pilot whales (*G. macrorhynchus*) persisted for life, but males sometimes left the pod at puberty to join bachelor groups.

The reason for the absence of dispersal in the resident form remains unclear. It could result from a particularly strong requirement that reliable and familiar associates be available for hunting or maintaining territorial boundaries. It could also result from a unique breeding strategy.

The absence of dispersal in resident whales may not be characteristic for all populations of the species. Although the social system of the transient form of the killer whale has not yet been examined in detail, it clearly differs from that of the resident form (Bigg *et al.*, 1987). The transient system is similar to that of residents in that offspring appear to maintain long-term bonds with their mothers. Analyses similar to those presented in this paper have indicated that transient pods comprise matrilineal groups spanning up to three generations; again no instances of individuals immigrating into these natal groups have been documented. However, in contrast to the resident form, there appears to be some dispersal of transient matrilineal groups and possibly of individuals. The transient pods are smaller (1-7 individuals; mean=2.7) than those of resident pods (3-49; mean=12.3) and each pod appears to contain no more than one matrilineal group. Thus, the matrilineal groups of the transient form presumably disperse. There also appears to be dispersal of individuals. At least one juvenile male (M03) left its pod and travelled alone. Moreover, a number of transient pods were comprised of solitary adult males.

The resident and transient forms exhibit many other behavioural differences as well as morphological differences (Bigg, Ford and Ellis, 1985; Bigg *et al.*, 1987; Baird and Stacey, 1988; Heimlich-Boran, J.R., 1988; Morton, 1990; Felleman, Heimlich-Boran, J.R., and Osborne, in press). A striking difference in their foraging habits may be an important determinant of their differences in social behaviour. MacDonald (1983) reported that foraging patterns can influence social organization in mammals. Transients feed extensively on marine mammals, whereas residents feed mainly on fish.

Although transients have been observed in the same vicinity that residents were feeding on salmon, transients appeared to ignore this food source. Conversely, residents have been observed in close proximity to other species of marine mammals, but ignored this prey.

The different strategies required to hunt marine mammals and fish may have resulted in the development of other behavioural differences. The large pods of the resident form may be more efficient at locating prey that has a patchy distribution, such as salmon. The predictable travel patterns observed in resident pods, their seasonal movements and congregation in Johnstone and Haro Straits during summer months may reflect the familiarity of residents with the seasonal migration routes of salmon. Conversely, the small pods of the transient form may be more efficient at capturing prey that occur in small groups, such as seals, sea lions and porpoises. The irregular travel and dive patterns and infrequent vocalizations which characterize transients may be part of their strategy to hunt wary prey. The fact that the transients and residents are sympatric but do not mix, probably reflects the non-competitiveness of their foraging strategies. On the other hand, the existence of separate ranges for the southern and northern communities suggests competition and this exclusion exists between resident communities.

Additional studies will be required to ascertain how representative our findings on the resident and transient social systems are of killer whales in other regions. Photo-identification studies indicate that both resident and transient forms of killer whales occur in the eastern Gulf of Alaska (Leatherwood, Balcomb, Matkin and Ellis, 1984; von Ziegeler, Ellis, Matkin and Goodwin, 1986). Preliminary analysis of the Alaskan data by one of us (G.M.E.) suggests that the resident pods were comprised of intra-pod groups similar to those in our study, but genealogies have not been examined. Photo-identification studies in Iceland, Norway and the Crozet Archipelago indicate that killer whales travelled in stable groups of 5–29 individuals (Lyrholm, Leatherwood and Sigurjónsson, 1987; Sigurjónsson, Lyrholm, Leatherwood, Jonsson and Vikingsson, 1988; Lyrholm, 1988; Lein J., Christensen, Lein M. and Jones, 1988; Guinet, 1988). However, none of these studies established whether more than one form of killer whale occurred or whether intra-pod groups were present.

Berzin and Vladimirov (1983) used carcasses and field observations to report the existence of a second species of killer whale in the Antarctic, termed *O. glacialis*. However, the new species designation has not been generally accepted (Heyning and Dahlheim, 1988). They reported that the *O. orca* form travelled in groups of 10–15 individuals and fed extensively on marine mammals and the *O. glacialis* form travelled in groups of 150–200 and fed mainly on fish. Thus, the *O. orca* form resembles transients and the *O. glacialis* form resembles residents. As with the residents and transients, the two Antarctic forms occurred in the same vicinity, but did not mix.

The fact that different social systems exist within a species is not unusual. Some species alter their behaviour depending on the environmental circumstances and may alternate between territorial and nonterritorial, monogamy and polyandry or large and small groups (Lott, 1984). Behavioural variations can also result from differences in genotypes, experience or culture and may change daily or gradually over many years. However, it is unusual to find variations in social systems at the same

place and time in one species, as exists in the resident and transient forms of killer whale. Perhaps this species has been able to evolve sympatric races that have different behaviours through strong social isolation. Strong social isolation existed at each level of social organization that we observed in the resident form. The species is intelligent, long-lived and has long-term maternal bonds and these features would make learning and traditions important components in the development of social isolation. Thus, localized populations may well have developed a range of social systems over the cosmopolitan distribution of this species.

ACKNOWLEDGEMENTS

This work was undertaken with the help of many dedicated associates. Over the years the following people provided a large number of photographs or field observations: D. Bain, R. Baird, K. Balcomb-Bartok, L. Barrett-Lennard, R. Chandler, B. Curtis, J. Darling, D. De Rousie, F. Felleman, C. Goebel, N. Haenal, S. Healy, S. and J. Heimlich-Boran, K. Heise, R. and K. Hobbs, R. Hoelzel, J. Jacobsen, M. Lough, E. Mathews, A. Morton, R. Osborne, P. Stacey, The Whale Museum, B. Todd, J. Waite, E. White, C. Whiting and C. Young. Several thousand people helped us locate whales by calling us whenever they saw them and often took photographs of the whales for us.

Particular thanks go to I. MacAskie who made important contributions to the project during the early years. Also, the insightful observations of D. Bain and the many discussions with him have contributed substantially to our understanding of the social organization and genealogies within the northern community of killer whales.

We are indebted to the following organizations for financial or logistic support for this work: Arctic Biological Station, Department of Fisheries and Oceans, Ste. Anne de Bellevue, Quebec; Center for Whale Research, Friday Harbor, Washington; Confidence Foundation, South Pasadena, California; Department of Supply and Services, Department of Fisheries and Oceans, Ottawa, Ontario; Department of Zoology, University of British Columbia, Vancouver, British Columbia; Island Foundation, Marion, Massachusetts; National Marine Mammal Laboratory, Seattle, Washington; Pacific Biological Station, Department of Fisheries and Oceans, Nanaimo, British Columbia; Sealand of the Pacific, Victoria, British Columbia; Stubbs Island Charters, Telegraph Cove, British Columbia; Vancouver Public Aquarium, Vancouver, British Columbia; and West Coast Whale Research Foundation, Vancouver, British Columbia.

We also thank two anonymous reviewers for critical comments.

REFERENCES

- Baird, R. W. and Stacey, P. J. 1988. Foraging and feeding behavior of transient killer whales. *Whalewatcher (J. Amer. Cetacean Soc.)* 22:11–15.
- Balcomb, K. C., Boran, J. R. and Heimlich, S. L. 1982. Killer whales in Greater Puget Sound. *Rep. int. Whal. Commn* 32: 681–5.
- Balcomb K. C. and Bigg, M. A. 1986. Population biology of the three resident killer whale pods in Puget Sound and off southern Vancouver Island, pp. 85–95. *In*: B. C. Kirkevold and J. S. Lockard (eds.) *Behavioral Biology of Killer Whales*. Zoo Biology Monographs, Vol. 1. Alan R. Liss, Inc. New York, N. Y. 457pp.

- Berzin, A. A. and Vladimirov, V. L. 1983. A new species of killer whale (Cetacea, Delphinidae) from Antarctic waters. *Zool. Zh.* 62: 287-95. (Translated by S. Pearson, Natl. Marine Mammal Laboratory, Seattle, Washington).
- Bigg, M. A. 1982. An assessment of killer whale (*Orcinus orca*) stocks off Vancouver Island, British Columbia. *Rep. int. Whal. Commn* 32: 655-66.
- Bigg, M. A., Ellis, G. and Balcomb, K. C. 1986. The photographic identification of individual cetaceans. *Whalewatcher (J. Amer. Cetacean Soc.)* 20: 10-12.
- Bigg, M. A., Ellis, G.M., Ford, J. K. B. and Balcomb, K.C. 1987. *Killer Whales: A Study of their Identification, Genealogy and Natural History in British Columbia and Washington State*. Phantom Press, Nanaimo, British Columbia. 79pp.
- Bigg, M.A., Ford, J. K. B. and Ellis, G. M. 1985. Two sympatric forms of killer whales off British Columbia and Washington. Presented to the Sixth Conference on the Biology of Marine Mammals, Vancouver, Canada, November 1985 (unpublished).
- Bigg, M. A. and Wolman, A. A. 1975. Live-capture killer whale (*Orcinus orca*) fishery, British Columbia and Washington State 1962-72. *J. Fish. Res. Bd Can.* 32: 1213-21.
- Chepko-Sade, B. D. and Sade, D. S. 1979. Patterns of group splitting within matrilineal kinship groups. *Behav. Ecol. Sociobiol.* 5: 67-86.
- Cole, L. C. 1949. The measurement of interspecific association. *Ecol.* 30: 411-24.
- Felleman, F. L., Heimlich-Boran, J. R. and Osborne, R. *In press*. Feeding ecology of the killer whale (*Orcinus orca*) in the Pacific Northwest. In: K. Pryor and K.S. Norris (eds.). *Dolphin Societies and How We Study Them*. Univ. Calif. Press, Calif., Berkeley.
- Ford J. K. B. 1984. Call traditions and dialects of killer whales (*Orcinus orca*) in British Columbia. PhD thesis, University of British Columbia, Vancouver, British Columbia. 435pp.
- Ford, J. K. B. and Fisher, H. D. 1982. Killer whale (*Orcinus orca*) dialects as an indicator of stocks in British Columbia. *Rep. int. Whal. Commn* 32: 671-9.
- Ford, J. K. B. and Fisher, H. D. 1983. Group-specific dialects of killer whales (*Orcinus orca*) in British Columbia, pp. 129-61. In: R. Payne (ed.) *Communication and Behavior of whales*. AAAS Selected Symposium 76. Boulder, Co. 643pp.
- Greenwood, P. J. 1980. Mating systems, philopatry and dispersal in birds and mammals. *Anim. Behav.* 28: 1140-62.
- Guinet, G. 1988. Historique de la presence d'orgues autour de L'Ile de la Possession, Archipel Crozet: 1964-1986. *Mammalia* 52 (2): 285-9.
- Haenel, N. J. 1986. General notes on the behavioral ontogeny of Puget Sound killer whales and the occurrence of allomaternal behavior, pp. 285-300. In: B.C. Kirkevold and J.S. Lockard (eds.) *Behavioral Biology of Killer Whales*. Zoo Biology Monographs, Vol. 1. Alan R. Liss, Inc. New York, N. Y. 457pp.
- Heimlich-Boran, J. R. 1986. Fishery correlations with the occurrence of killer whales in greater Puget Sound, pp. 113-31. In: B.C. Kirkevold and J.S. Lockard (eds.) *Behavioral Biology of Killer Whales*. Zoo Biology Monographs, Vol. 1. Alan R. Liss, Inc. New York, N. Y. 457pp.
- Heimlich-Boran, J. R. 1988. Behavioral ecology of killer whales (*Orcinus orca*) in the Pacific Northwest. *Can. J. Zool.* 66: 565-78.
- Heimlich-Boran, S. L. 1986. Cohesive relationships among Puget Sound killer whales, pp. 251-84. In: B.C. Kirkevold and J.S. Lockard (eds.) *Behavioral Biology of Killer Whales*. Zoo Biology Monographs, Vol. 1. Alan R. Liss, Inc. New York, N. Y. 457pp.
- Heyning, J. E. and Dahlheim, M. E. 1988. Mammalian species No. 304, *Orcinus orca*. *Amer. Soc. Mammalogists*. 15 (January 1988): 1-9.
- Jacobsen, J. K. 1986. The behavior of *Orcinus orca* in Johnstone Strait, British Columbia, pp. 135-85. In: B.C. Kirkevold and J.S. Lockard (eds.) *Behavioral Biology of Killer Whales*. Zoo Biology Monographs, Vol. 1. Alan R. Liss, Inc. New York, N. Y. 457pp.
- Jeune, P. 1979. *Killer whale, the Saga of Miracle*. McClelland, Toronto. 190pp.
- Johnson, S. C. 1967. Hierarchical clustering schemes. *Psychometrika* 32: 241-54.
- Kendall, M. G. and Stuart, A. 1967. *The Advanced Theory of Statistics. Vol. 2. Inference and relationship*. Hafner Publ. Co., New York. 690pp.
- Kasuya, T. and Marsh, H. 1984. Life history and reproductive biology of the short-finned pilot whale, *Globicephala macrorhynchus*, off the Pacific coast of Japan. *Rep. int. Whal. Commn* (special issue 6): 259-310.
- Kurland, J. A. 1977. Kin selection in the Japanese monkey. *Contrib. Primatol.* 12. Basel: Karger.
- Landino, S. W. 1985. Cetacean breeding systems revealed by interspecific comparison. Presented to the Sixth Conference on the Biology of Marine Mammals, Vancouver, Canada, November 1985 (unpublished).
- Leatherwood, S., Balcomb K. C. III, Matkin, C. O. and Ellis, G. 1984. Killer whales (*Orcinus orca*) of southern Alaska. Results of Field Research 1984. Prel. Rep. Hubbs Sea World Research Institute Technical Report No. 84-175. 59pp.
- Lien, J., Christensen I., Lien, M. and Jones, P.W. 1988. A note on killer whales (*Orcinus orca*) near Svolvær, Norway in November-December, 1984. *Rit. Fisk.* 11:95-8
- Lott, D. F. 1984. Intraspecific variation in the social systems of wild vertebrates. *Behaviour* 88: 266-325.
- Lyrholm, T., Leatherwood, S. and Sigurjónsson, S. 1987. Photo-identification of killer whales (*Orcinus orca*) off Iceland, October 1985. *Cetology* 52: 1-14.
- Lyrholm, T. 1988. Photo-identification of killer whales, (*Orcinus orca*) off the coast of Norway, 1983-86. *Rit. Fisk.* 11:89-94
- MacDonald, D. W. 1983. The ecology of carnivore social behaviour. *Nature* 301: 379-84.
- Morton, A. 1985. The development of an ethogram for the northern Vancouver Island, British Columbia, *Orcinus orca* during the fall, winter and spring. *Cetus* 6 (1): 17.
- Morton, A. 1990. A quantitative comparison of behaviour in resident and transient killer whales of the central British Columbia coast. Paper SC/A88/P17 (published in this volume).
- Norris, K. S. and Dohl, T. P. 1980. Structure and function of cetacean schools, pp. 211-61. In: L. M. Herman (ed) *Cetacean Behavior: mechanisms and functions*. John Wiley and Sons, Inc., New York, N. Y. 463pp.
- Olesiuk, P. F., Bigg, M. A. and Ellis, G. 1990. Life history and population dynamics of resident killer whales (*Orcinus orca*) in the coastal waters of British Columbia and Washington State. Paper SC/A88/ID3 (published in this volume).
- Osborne, R. W. 1986. A behavioral budget of Puget Sound killer whales, pp. 211-49. In: B. C. Kirkevold and J.S. Lockard (eds.) *Behavioral Biology of Killer Whales*. Zoo Biology Monographs, Vol. 1. Alan R. Liss, Inc. New York, N. Y. 457pp.
- Osborne, R., Calambokidis, J. and Dorsey, E. M. 1988. *A Guide to Marine Mammals of Greater Puget Sound, including a Catalog of Individual Orca and Minke Whales*. Island Publishers. Anacortes, Washington. 191pp.
- Poole, R. W. 1974. *An Introduction to Quantitative Ecology*. McGraw-Hill Book Co., New York. 532pp.
- Ridgway, S. H. and Harrison, R. J. (eds.). 1981a. *Handbook of Marine Mammals. Vol. 1. The Walrus, Sea Lions, Fur Seals and Sea Otter*. Academic Press, London. 235pp.
- Ridgway, S. H. and Harrison R. J. (eds.). 1981b. *Handbook of Marine Mammals. Vol. 2. Seals*. Academic Press, London. 359pp.
- Sigurjónsson, J., Lyrholm, T., Leatherwood, S., Jonsson, E. and Vikingsson, G. 1988. Photo-identification of killer whales, *Orcinus orca*, off Iceland, 1981 through 1986. *Rit. Fisk.* 11:99-114.
- Sugarman, P. 1984. *Field Guide to the Orca Whales of Greater Puget Sound and Southern British Columbia*. The Whale Museum, Friday Harbor, Washington. 27pp.
- Trivers, R. 1985. *Social Evolution*. Benjamin Cummings, Menlo Park, California. 429pp.
- von Ziegeler, O., Ellis, G., Matkin, C. and Goodwin, B. 1986. Repeated sightings of identifiable killer whales (*Orcinus orca*) in Prince William Sound, Alaska 1977-1983. *Cetus* 6(2): 9-13.
- Wells, R. S., Irvine, A. B. and Scott, M. D. 1980. The social ecology of inshore odontocetes, pp. 263-317. In: L. M. Herman (ed) *Cetacean Behavior: Mechanisms and Functions*. John Wiley and Sons, Inc., New York, N. Y. 463pp.

Appendix

DATA ON EACH INDIVIDUAL IN BOTH COMMUNITIES

KEY TO APPENDIX TABLES A AND B

1. **Pod (Sub-MAT):** the individual's pod, subpod and matrilineal (intra-pod) group.
2. **ID:** the individual's identification code.
3. **Mom:** the individual's mother. Mothers were identified on the basis of both direct observations and CAI values, unless indicated with superscripts: a- mother assigned solely on the basis of association analysis; d- mother assigned solely on the basis of direct observations.
4. **Sex:** M= male; F=female; ?=sex unknown
5. **Cat:** the category of the individual at start of study (and the level of certainty of the identity its mother - see Section 4.1): B- born during study (positive). J- juvenile at the start of the study; sexually immature for females and physically immature for males (highly probable). A- adult at the start of the study; sexually mature for females and physically mature for males (probable).
6. **Min.Age:** the year of birth used to estimate the minimum age of individuals (see Section 2.4.2). Superscripts denote the method used to establish the latest possible year of birth; all births between June and July were assumed to have taken place on 1 January: b- year of birth known; e- estimated based on body-size when first seen; m- estimated by subtracting mean age at maturity from year matured; o- estimated by subtracting mean age of maturity from age of oldest presumed offspring; p- estimated by subtracting mean age of physical maturity from year first seen as physically mature animal.
7. **Est.Age:** the year of birth used to estimate the actual age of individuals in Olesiuk and Bigg (1990). Superscripts denote the ageing method used and nominal accuracy of the age estimates as given in Table 3.1 of Olesiuk and Bigg (1990). Although these estimates are considered to be the most accurate, they were not utilized in the construction of the genealogical trees because they were derived subsequent to the genealogies.
8. **First:** the year in which the individual was first identified, which in most cases represents the year its pod was first encountered. However, individuals were sometimes identified in photographs taken prior to the start of the study.
9. **Last:** the year in which the individual was last seen.
10. **Died:** the year, or range of years, in which the individual died; Superscripts denote the following special cases: c- taken in live-capture fishery prior to start of the study; n- died as neonate (i.e. <0.5 years of age).

Appendix Table A

Registry of all individuals in the southern resident community.

Pod(Sub-MAT)										Year of birth					Seen				
Pod(Sub-MAT)	ID	Mom	Sex	Cat	Min.Age	Est.Age	First	Last	Died	Pod(Sub-MAT)	ID	Mom	Sex	Cat	Min.Age	Est.Age	First	Last	Died
J01(J01-J01)	J01		M	A	≤ 1951 ^P	≤ 1951 ⁱ	1972	1987		K01(K18-K18)	K21	K18	?	B	1986 ^b	1986 ^a	1986	1987	
J01(J01-J01)	J02		F	A	≤ 1942 ^o	1911 ^f	1972	1987		K01(K18-K30)	K30		F	A	≤ 1938 ^o	1929 ^f	1974	1982	1982
J01(J01-J01)	J12	J02	F	A	≤ 1957 ^o	1935 ^e	1972	1987		K01(K18-K30)	K19	K30	M	A	≤ 1953 ^P	≤ 1953 ⁱ	1974	1984	1984
J01(J01-J01)	J24	J12	?	-	1972 ^b	-	1972	1972	1972 ^c	L01(L08-L07)	L07	L37 ^a	F	A	≤ 1962 ^o	1961 ^c	1971	1987	
J01(J01-J01)	J14	J12	F	B	1974 ^b	1974 ^a	1974	1987		L01(L08-L07)	L53	L07	?	B	1977 ^b	1977 ^a	1977	1987	
J01(J01-J01)	J23	J14	?	B	1987 ^b	1987 ^a	1987	1987		L01(L08-L07)	L76	L07	?	B	1987 ^b	1987 ^a	1987	1987	
J01(J01-J04)	J06		M	J	1956 ^m	1956 ^b	1969	1987		L01(L08-L26)	L16		M	A	≤ 1949 ^p	≤ 1949 ⁱ	1970	1978	1978
J01(J01-J04)	J08		F	A	≤ 1942-3 ^o	1933 ^f	1968	1987		L01(L08-L26)	L26		F	A	≤ 1957-8 ^o	1956 ^f	1971	1987	
J01(J01-J04)	J04	J08	F	A	≤ 1957-8 ^o	1957 ^d	1968	1987		L01(L08-L26)	L60	L26	F	J	1972-3 ^e	1972-3 ^b	1974	1987	
J01(J01-J04)	J11	J04	F	J	1972-3 ^e	1972-3 ^b	1974	1987		L01(L08-L26)	L52	L26	?	B	1980 ^b	1980 ^a	1980	1983	1983
J01(J01-J04)	J15	J04	M	B	1976 ^b	1976 ^a	1976	1981	1981	L01(L08-L26)	L71	L26	?	B	1986 ^b	1986 ^a	1986	1987	
J01(J01-J04)	J19	J04	F	B	1979 ^b	1979 ^a	1979	1987		L01(L08-L37)	L37		F	A	≤ 1957 ^o	1933 ^e	1974	1984	1984
J01(J01-J04)	J21	J04	?	B	1982 ^b	1982 ^a	1982	1983	1983	L01(L08-L37)	L43	L37	F	J	1972 ^e	1972 ^b	1974	1987	
J01(J01-J07)	J07		F	A	≤ 1938 ^o	1939 ^f	1972	1983	1983	L01(L08-L37)	L72	L43	?	B	1986 ^b	1986 ^a	1986	1987	
J01(J01-J07)	J03	J07	M	J	1953 ^m	1953 ^b	1968	1987		L01(L08-L21)	L21		F	A	≤ 1959 ^o	1938 ^e	1974	1987	
J01(J01-J07)	J16	J07	F	J	1972-3 ^e	1972-3 ^b	1974	1987		L01(L08-L21)	L47	L21	F	B	1974 ^b	1974 ^a	1974	1987	
J01(J01-J05)	J05	J09	F	A	≤ 1956-7 ^o	1938 ^e	1968	1987		L01(L08-L21)	L48	L21	?	B	1977 ^b	1977 ^a	1977	1983	1983
J01(J01-J05)	J13	J05	F	J	1971-2 ^e	1971-2 ^b	1974	1980	1980	L01(L08-L25)	L25		F	A	≤ 1942-3 ^o	1928 ^f	1974	1987	
J01(J01-J05)	J17	J05	F	B	1977 ^b	1977 ^a	1977	1987		L01(L08-L25)	L23	L25	F	A	≤ 1957-8 ^o	1952 ^f	1974	1982	1982
J01(J01-J09)	J09		F	A	≤ 1941-2 ^o	1917 ^d	1972	1985	1985	L01(L08-L25)	L14	L23	M	J	1972-3 ^e	1972-3 ^b	1974	1987	
J01(J01-J09)	J10	J09	F	A	≤ 1963 ^o	1962 ^c	1972	1987		L01(L08-L25)	L49	L23	?	B	1979 ^b	1979 ^a	1979	1980	1980
J01(J01-J09)	J18	J10	M	B	1978 ^b	1978 ^a	1978	1987		L01(L08-L08)	L45	L66	F	A	≤ 1960 ^o	1938 ^e	1974	1987	
J01(J01-J09)	J20	J10	?	B	1981 ^b	1981 ^a	1981	1987		L01(L08-L08)	L36	L45	?	B	1975 ^b	1975 ^a	1975	1975	1975 ⁿ
J01(J01-J09)	J22	J10	F	B	1985 ^b	1985 ^a	1985	1987		L01(L08-L08)	L57	L45	M	B	1977 ^b	1977 ^a	1977	1987	
K01(K01-K04)	K04		F	A	≤ 1956-7 ^o	1933 ^e	1974	1987		L01(L08-L08)	L08	L66	M	J	1958 ^m	1958 ^b	1970	1977	1977
K01(K01-K04)	K12	K04	F	J	1971-2 ^e	1971-2 ^b	1974	1987		L01(L08-L04)	L04		F	A	≤ 1950 ^o	1938 ^e	1974	1987	
K01(K01-K04)	K22	K12	?	B	1987 ^b	1987 ^a	1987	1987		L01(L08-L04)	L61	L04	M	J	1973 ^e	1973 ^b	1974	1987	
K01(K01-K08)	K08		F	A	≤ 1938 ^o	1930 ^f	1967	1987		L01(L08-L04)	L55	L04	?	B	1977 ^b	1977 ^a	1977	1987	
K01(K01-K08)	K05	K08	M	J	1953 ^m	1953 ^b	1967	1987		L01(L08-L27)	L27	L04	F	A	≤ 1965 ^o	1965 ^c	1974	1987	
K01(K01-K08)	K03	K08	F	A	≤ 1956-7 ^o	1954 ⁱ	1974	1987		L01(L08-L27)	L62	L27	?	B	1980 ^b	1980 ^a	1980	1987	
K01(K01-K08)	K15	K03	?	J	1971-2 ^e	1971-2 ^b	1974	1975	1975	L01(L08-L27)	L68	L27	?	B	1985 ^b	1985 ^a	1985	1987	
K01(K01-K08)	K14	K03	M	B	1977 ^b	1977 ^a	1977	1987		L01(L08-L02)	L02		F	A	≤ 1947 ^o	1945 ^d	1974	1987	
K01(K01-K08)	K16	K03	?	B	1985 ^b	1985 ^a	1985	1987		L01(L08-L02)	L06	L02	M	J	1962 ^m	1962 ^b	1974	1983	1983
K01(K01-K01)	K07		F	A	≤ 1938 ^o	1910 ^d	1972	1987		L01(L08-L02)	L39	L02	M	B	1975 ^b	1975 ^a	1975	1987	
K01(K01-K01)	K02	K07	M	A	≤ 1953 ^P	≤ 1953 ⁱ	1974	1974	1974	L01(L08-L02)	L67	L02	?	B	1985 ^b	1985 ^a	1985	1987	
K01(K01-K01)	K01	K07 ^a	M	J	1955 ^m	1955 ^b	1967	1987		L01(L08-L03)	L03	L09	F	A	≤ 1948 ^o	1946 ^d	1974	1987	
K01(K01-K01)	K11	K07 ^a	F	A	≤ 1957 ^o	1933 ^e	1974	1987		L01(L08-L03)	L33	L03	M	J	1963 ^m	1963 ^b	1974	1987	
K01(K01-K01)	K13	K11	F	J	1972 ^e	1972 ^b	1974	1987		L01(L08-L03)	L51	L03	F	J	1973-4 ^c	1973-4 ^b	1974	1987	
K01(K01-K01)	K20	K13	?	B	1986 ^b	1986 ^a	1986	1987		L01(L08-L03)	L59	L03	?	B	1979 ^b	1979 ^a	1979	1979	1979 ⁿ
K01(K18-K18)	K18		F	A	≤ 1950 ^o	1948 ^d	1974	1987		L01(L08-L03)	L74	L03	?	B	1986 ^b	1986 ^a	1986	1987	
K01(K18-K18)	K40	K18	F	J	1965 ^e	1965 ^b	1974	1987		L01(L08-L09)	L09		F	A	≤ 1933 ^o	1931 ^f	1974	1987	
K01(K18-K18)	K17	K18	M	J	1966 ^m	1966 ^b	1974	1987		L01(L08-L09)	L05	L09	F	A	≤ 1965 ^o	1964 ^c	1974	1987	
K01(K18-K18)	K46	K18	?	B	1974 ^b	1974 ^a	1974	1981	1981	L01(L08-L09)	L58	L05	?	B	1980 ^b	1980 ^a	1980	1987	

[continued]

Pod(Sub-MAT)	ID	Mom	Sex	Cat	Year of birth		Seen		
					Min.Age	Est.Age	First	Last	Died
L01(L08-L09)	L73	L05	?	B	1986 ^b	1986 ^a	1986	1987	
L01(L10-L10)	L12		F	A	≤ 1943 ^o	1933 ^f	1974	1987	
L01(L10-L10)	L11	L12	F	A	≤ 1958 ^o	1957 ^d	1974	1987	
L01(L10-L10)	L42	L11 ^d	M	J	1973 ^e	1973 ^b	1974	1987	
L01(L10-L10)	L41	L11	M	B	1977 ^b	1977 ^a	1977	1987	
L01(L10-L10)	L64	L11	?	B	1985 ^b	1985 ^a	1985	1985	1985
L01(L10-L10)	L77	L11	?	B	1987 ^b	1987 ^a	1987	1987	
L01(L10-L28)	L10	L12 ^a	M	J	1959 ^m	1959 ^g	1973	1987	
L01(L10-L28)	L28		F	A	≤ 1935 ^o	1924 ^f	1974	1987	
L01(L10-L28)	L32	L28	F	A	≤ 1950 ^o	1948 ^d	1973	1987	
L01(L10-L28)	L38	L32 ^d	M	J	1965 ^m	1965 ^g	1974	1987	
L01(L10-L28)	L22	L32	F	J	1971 ^e	1971 ^b	1974	1987	
L01(L10-L28)	L75	L22	?	B	1986 ^b	1986 ^a	1986	1987	
L01(L10-L28)	L44	L32	M	B	1974 ^b	1974 ^a	1974	1987	

Pod(Sub-MAT)	ID	Mom	Sex	Cat	Year of birth		Seen		
					Min.Age	Est.Age	First	Last	Died
L01(L10-L28)	L56	L32	?	B	1978 ^b	1978 ^a	1978	1981	1981
L01(L10-L28)	L69	L32	?	B	1984 ^b	1984 ^a	1984	1985	1985
L01(L10-L28)	L63	L32	?	B	1984 ^b	1984 ^a	1984	1987	
L01(L10-L15)	L15		F	A	≤ 1937 ^o	1930 ^f	1974	1981	1981
L01(L10-L15)	L13	L15	M	A	≤ 1952 ^p	≤ 1952 ⁱ	1973	1980	1980
L01(L10-L15)	L20	L15	M	J	1955 ^m	1955 ^g	1974	1982	1982
L01(L35-L35)	L35		F	A	≤ 1944 ^o	1942 ^d	1974	1987	
L01(L35-L35)	L01	L35	M	J	1959 ^m	1959 ^g	1974	1987	
L01(L35-L35)	L50	L35	M	J	1973 ^e	1973 ^b	1974	1987	
L01(L35-L35)	L54	L35	?	B	1977 ^b	1977 ^a	1977	1987	
L01(L35-L35)	L65	L35	?	B	1984 ^b	1984 ^a	1984	1987	
Unknown	B20		F	B	1977 ^b	1977 ^a	1977	1977	1977 ^c

Appendix Table B

Registry of all individuals in the northern resident community.

Pod(Sub-MAT)	ID	Mom	Sex	Cat	Year of birth		Seen		
					Min.Age	Est.Age	First	Last	Died
A01(A01-A01)	A01		F	A	≤ 1934 ^o	1927 ^d	1971	1974	1974
A01(A01-A01)	A36	A01	F	A	≤ 1949 ^o	1947 ^d	1972	1987	
A01(A01-A01)	A32	A36	M	J	1964 ^m	1964 ^g	1973	1987	
A01(A01-A01)	A44	A36 ^d	F	B	1973 ^b	1973 ^a	1973	1975	1975
A01(A01-A01)	A37	A36	M	B	1977 ^e	1977 ^b	1978	1987	
A01(A01-A01)	A46	A36	?	B	1982 ^b	1982 ^a	1982	1987	
A01(A01-A01)	A20	A01	M	J	1953 ^m	1953 ^g	1973	1987	
A01(A02-A02)	A02		F	A	≤ 1934 ^o	1927 ^d	1972	1987	
A01(A02-A02)	A30	A02	F	A	≤ 1949 ^o	1947 ^d	1973	1987	
A01(A02-A02)	A06	A30	M	J	1964 ^m	1964 ^g	1973	1987	
A01(A02-A02)	A38	A30	M	J	1970-1 ^c	1970-1 ^b	1973	1987	
A01(A02-A02)	A39	A30	M	B	1975 ^e	1975 ^b	1976	1987	
A01(A02-A02)	A40	A30	?	B	1981 ^b	1981 ^a	1981	1983	1983
A01(A02-A02)	A50	A30	F	B	1984 ^b	1984 ^a	1984	1987	
A01(A02-A02)	A03	A02	M	A	≤ 1952 ^p	≤ 1952 ⁱ	1973	1979	1979
A01(A12-A12)	A12		F	A	≤ 1943 ^o	1941 ^d	1973	1987	
A01(A12-A12)	A31	A12	M	J	1958 ^m	1958 ^g	1973	1987	
A01(A12-A12)	A33	A12	M	J	1971 ^e	1971 ^b	1973	1987	
A01(A12-A12)	A34	A12	F	B	1975 ^b	1975 ^a	1975	1987	
A04(A24-A04)	A10		F	A	≤ 1944 ^o	1941 ^d	1973	1983	1983
A04(A24-A04)	A24	A10	F	J	1967 ^e	1967 ^b	1973	1987	
A04(A24-A04)	A41	A24 ^d	?	B	1981 ^b	1981 ^a	1981	1981	1981 ⁿ
A04(A24-A04)	A45	A24	?	B	1983 ^b	1983 ^a	1983	1987	
A04(A24-A04)	A49	A24	?	B	1985 ^b	1985 ^a	1985	1986	1986
A04(A24-A04)	A19	A10	?	B	1973 ^b	1973 ^a	1973	1973	1973
A04(A24-A04)	A47	A10	?	B	1983 ^b	1983 ^a	1983	1983	1983
A04(A24-A04)	A04		M	A	≤ 1952 ^p	≤ 1952 ⁱ	1973	1984	1984
A04(A11-A11)	A11	A10	F	A	≤ 1959 ^o	1958 ^d	1973	1987	
A04(A11-A11)	A35	A11	F	B	1974 ^b	1974 ^a	1974	1987	
A04(A11-A11)	A52	A35	?	B	1987 ^b	1987 ^a	1987	1987	
A04(A11-A11)	A13	A11	M	B	1978 ^b	1978 ^a	1978	1987	
A04(A11-A11)	A48	A11	?	B	1983 ^b	1983 ^a	1983	1987	
A05(A14-A14)	A14		F	A	≤ 1949 ^o	1947 ^d	1968	1987	
A05(A14-A14)	A17	A14	?	-	1964 ^e	-	1968	1968	1969 ^c
A05(A14-A14)	A18	A14	F	-	1969 ^e	-	1969	1969	1969 ^c
A05(A14-A14)	A25	A14	F	J	1971-2 ^e	1971-2 ^b	1973	1987	
A05(A14-A14)	A51	A25	?	B	1986 ^b	1986 ^a	1986	1987	
A05(A14-A14)	A15	A14	M	B	1979 ^b	1979 ^f	1979	1987	
A05(A14-A07)	A07		F	A	≤ 1934 ^o	1927 ^d	1969	1977	1977
A05(A14-A07)	A23	A07	F	A	≤ 1949 ^o	1947 ^d	1969	1987	
A05(A14-A07)	A16	A23	F	-	1964 ^e	-	1969	1969	1969 ^c
A05(A14-A07)	A21	A23	?	J	1967 ^e 1967 ^b	1973	1973	1973	
A05(A14-A07)	A27	A23	M	J	1971-2 ^e	1971-2 ^b	1973	1987	
A05(A14-A07)	A29	A23	?	B	1977 ^b	1977 ^a	1977	1980	1980
A05(A14-A07)	A43	A23	?	B	1981 ^b	1981 ^a	1981	1987	
A05(A05-A09)	A09		F	A	≤ 1942 ^o	1937 ^f	1973	1987	
A05(A05-A09)	A05	A09	M	J	1957 ^m	1957 ^g	1969	1987	
A05(A05-A09)	A26	A09	M	J	1971-2 ^e	1971-2 ^b	1973	1987	
A05(A05-A08)	A08	A09	F	A	≤ 1959 ^o	1953 ^f	1969	1987	
A05(A05-A08)	A28	A08	F	B	1974 ^b	1974 ^a	1974	1987	
A05(A05-A08)	A42	A08	F	B	1980 ^b	1980 ^a	1980	1987	
B01(B01-B01)	B11		F	A	≤ 1934 ^o	1927 ^d	1973	1973	1973
B01(B01-B01)	B07	B11	F	A	≤ 1949 ^o	1947 ^d	1973	1987	
B01(B01-B01)	B08	B07	M	J	1964 ^m	1964 ^g	1973	1987	
B01(B01-B01)	B10	B07	M	B	1979 ^b	1979 ^a	1979	1987	
B01(B01-B01)	B12	B07	?	B	1984 ^b	1984 ^a	1984	1987	
B01(B01-B01)	B13	B07 ^d	?	B	1987 ^b	1987 ^a	1987	1987	
B01(B01-B01)	B01	B11	M	A	≤ 1951 ^p	≤ 1951 ⁱ	1972	1987	

Pod(Sub-MAT)	ID	Mom	Sex	Cat	Year of birth		Seen		
					Min.Age	Est.Age	First	Last	Died
B01(B01-B01)	B03	B11	M	J	1958 ^m	1958 ^g	1973	1982	1982
B01(B01-B01)	B05	B11	M	J	1963 ^m	1963 ^g	1973	1985	1985
B01(B01-B01)	B06	B11 ^d	M	B	1973 ^b	1973 ^a	1973	1987	
B01(B01-B01)	B02		M	A	≤ 1952 ^p	≤ 1952 ⁱ	1973	1987	
C01(C01-C01)	C03		M	A	≤ 1952 ^p	≤ 1952 ⁱ	1973	1987	
C01(C01-C01)	C04		F	A	≤ 1941-2 ^o	1937 ^d	1973	1982	1982-4
C01(C01-C01)	C01	C04 ^a	M	A	≤ 1951 ^p	≤ 1951 ⁱ	1972	1980	1980-1
C01(C01-C01)	C06	C04	F	A	≤ 1956-7 ^o	1955 ^d	1973	1987	
C01(C01-C01)	C09	C06	M	J	1971-2 ^e	1971-2 ^b	1973	1987	
C01(C01-C01)	C08	C06	F	B	1975 ^b	1975 ^a	1975	1987	
C01(C01-C01)	C12	C06	?	B	1979 ^e	1979 ^b	1980	1987	1987
C01(C01-C01)	C14	C06	?	B	1985 ^b	1985 ^a	1985	1987	
C01(C01-C01)	C07		M	A	≤ 1951 ^p	≤ 1951 ⁱ	1972	1984	1984
C01(C05-C05)	C05		F	A	≤ 1930 ^o	1924 ^d	1965	1987	
C01(C05-C05)	C11	C05	M	-	1945 ^e	-	1965	1965	1965 ^c
C01(C05-C05)	C02	C05	M	J	1957 ^m	1957 ^g	1965	1986	1986
C01(C05-C05)	C15	C05	?	-	1964 ^e	-	1965	1965	1965-73
C01(C05-C05)	C10	C05	F	J	1971-2 ^e	1971-2 ^b	1973	1987	
C01(C05-C05)	C13	C10	?	B	1985 ^b	1985 ^a	1985	1987	
D01(D07-D07)	D07		F	A	≤ 1943 ^o	1941 ^d	1973	1987	
D01(D07-D07)	D04	D07	M	J	1958 ^m	1958 ^g	1973	1984	1984
D01(D07-D07)	D10	D07	?	B	1978 ^b	1978 ^a	1978	1987	
D01(D07-D07)	D13	D07	?	B	1984 ^b	1984 ^a	1984	1987	
D01(D07-D08)	D08	D07	F	J	1967 ^m	1967 ^g	1973	1987	
D01(D07-D08)	D12	D08	?	B	1982 ^b	1982 ^a	1982	1987	
D01(D07-D08)	D16	D08	?	B	1987 ^b	1987 ^a	1987	1987	
D01(D07-D08)	D09	D07	F	J	1971-2 ^e	1971-2 ^b	1973	1987	
D01(D07-D08)	D15	D09	?	B	1987 ^b	1987 ^a	1987	1987	
D01(D01-D01)	D03		F	A	≤ 1941 ^o	1939 ^d	1973	1987	
D01(D01-D01)	D02	D03	M	J	1956 ^m	1956 ^g	1973	1982	1982
D01(D01-D01)	D05	D03	M	J	1963 ^m	1963 ^g	1973	1987	
D01(D01-D01)	D11	D03	F	B	1975 ^b	1975 ^a	1975	1987	
D01(D01-D01)	D14	D11	?	B	1987 ^b	1987 ^a	1987	1987	
D01(D01-D01)	D01		M	A	≤ 1952 ^p	≤ 1952 ⁱ	1973	1981	1981
G01(G01-G01)	G01		M	A	≤ 1952 ^p	≤ 1952 ⁱ	1973	1978	1978-80
G01(G01-G01)	G03		F	A	≤ 1957 ^o	1956 ^d	1974	1987	
G01(G01-G01)	G20	G03	F	J	1972 ^e	1972 ^b	1974	1987	
G01(G01-G01)	G37	G20	?	B	1984 ^b				

Pod(Sub-MAT)	ID	Mom	Sex	Cat	Year of birth		Seen		
					Min.Age	Est.Age	First	Last	Died
G01(G04-G04)	G06	G04	M	J	1965 ^m	1965 ^b	1973	1987	
G01(G04-G04)	G26	G04	M	J	1970-1 ^c	1970-1 ^b	1973	1987	
G12(G12-G02)	G02		F	A	≤ 1962 ^o	1961 ^d	1973	1986	
G12(G12-G02)	G34	G02	?	B	1977 ^c	1977 ^b	1982	1985	
G12(G12-G02)	G28	G02	?	B	1981 ^b	1981 ^a	1981	1986	
G12(G12-G02)	G36	G02	?	B	1985 ^b	1985 ^d	1985	1986	
G12(G12-G12)	G12		F	A	≤ 1956 ^o	1955 ^d	1968	1987	
G12(G12-G12)	G08	G12	F	J	1971 ^c	1971 ^b	1973	1987	
G12(G12-G12)	G35	G08	?	B	1985 ^b	1985 ^a	1985	1987	
G12(G12-G12)	G27	G12	F	J	1973-4 ^e	1973-4 ^b	1974	1987	
G12(G12-G12)	G41	G27 ^d	?	B	1987 ^b	1987 ^a	1987	1987	
G12(G12-G12)	G33	G12	?	B	1978-9 ^e	1978-9 ^b	1981	1987	
G12(G12-G12)	G42	G12 ^d	?	B	1986 ^c	1986 ^b	1987	1987	
H01(H01-H01)	H06		F	A	≤ 1944-5 ^o	1942 ^d	1975	1987	
H01(H01-H01)	H03	H06	F	A	≤ 1959-60 ^o	1959 ^d	1974	1987	
H01(H01-H01)	H04	H03	M	J	1974-5 ^e	1974-5 ^b	1975	1987	
H01(H01-H01)	H07	H03	M	B	1981 ^b	1981 ^a	1981	1987	
H01(H01-H01)	H08	H03	?	B	1986 ^b	1986 ^a	1986	1987	
H01(H01-H01)	H02	H06	M	J	1965 ^m	1965 ^b	1974	1987	
H01(H01-H01)	H05	H06	F	J	1973 ^e	1973 ^b	1975	1987	
H01(H01-H01)	H01		M	A	≤ 1952 ^p	≤ 1952 ⁱ	1973	1982	1982
I01(I01-I01)	I01		F	A	≤ 1953 ^o	1952 ^d	1973	1986	
I01(I01-I01)	I19	I01	F	J	1968 ^m	1968 ^c	1975	1986	
I01(I01-I01)	I54	I19	?	B	1983 ^e	1983 ^b	1986	1986	
I01(I01-I01)	I56	I19	?	B	1986 ^b	1986 ^a	1986	1986	
I01(I01-I01)	I23	I01	M	J	1973-4 ^e	1973-4 ^b	1975	1986	
I01(I01-I01)	I40	I01	?	B	1980 ^b	1980 ^a	1980	1986	
I01(I01-I01)	I03		M	A	≤ 1954 ^p	≤ 1954 ⁱ	1975	1986	
I02(I02-I02)	I02		F	A	≤ 1939 ^o	1936 ^d	1975	1987	
I02(I02-I02)	I14	I02	M	A	≤ 1954 ^p	≤ 1954 ⁱ	1975	1987	
I02(I02-I02)	I05	I02	M	A	≤ 1954 ^p	≤ 1954 ⁱ	1975	1987	
I02(I02-I02)	I08	I02	M	J	1964 ^m	1964 ^b	1975	1987	
I02(I02-I02)	I28	I02	M	J	1974 ^c	1974 ^b	1975	1987	
I02(I02-I22)	I22	I02	F	J	1965 ^m	1965 ^c	1975	1987	
I02(I02-I22)	I39	I22	?	B	1980 ^e	1980 ^b	1981	1987	
I02(I02-I22)	I55	I22	?	B	1987 ^b	1987 ^a	1987	1987	
I11(I11-I11)	I11		F	A	≤ 1955 ^o	1954 ^d	1968	1987	
I11(I11-I11)	I12	I11	F	J	1970 ^m	1970 ^c	1975	1987	
I11(I11-I11)	I47	I12	?	B	1985 ^b	1985 ^a	1985	1987	
I11(I11-I11)	I13	I11	?	J	1974 ^c	1974 ^b	1975	1987	
I11(I11-I11)	I37	I11	?	B	1979 ^c	1979 ^b	1980	1987	
I11(I11-I11)	I42	I11	?	B	1983 ^b	1983 ^a	1983	1987	
I11(I15-I15)	I10		M	A	≤ 1947 ^p	≤ 1947 ⁱ	1968	1975	1975-7
I11(I15-I15)	I15		F	A	≤ 1953 ^o	1952 ^d	1975	1987	
I11(I15-I15)	I16	I15	F	J	1968 ^m	1968 ^c	1975	1987	
I11(I15-I15)	I43	I16	?	B	1983 ^b	1983 ^a	1983	1987	
I11(I15-I15)	I51	I16	?	B	1986 ^b	1986 ^a	1986	1987	
I11(I15-I15)	I27	I15	?	J	1974 ^c	1974 ^b	1975	1987	
I11(I15-I15)	I04	I15	?	B	1980 ^b	1980 ^a	1980	1987	
I11(I15-I15)	I41	I15	?	B	1980 ^e	1980 ^b	1981	1987	
I11(I15-I15)	I44	I15	?	B	1985 ^b	1985 ^a	1985	1987	

Pod(Sub-MAT)	ID	Mom	Sex	Cat	Year of birth		Seen		
					Min.Age	Est.Age	First	Last	Died
I18(I18-I18)	I18		F	A	≤ 1949 ^o	1947 ^d	1975	1986	
I18(I18-I18)	I20	I18	F	A	≤ 1964 ^o	1964 ^d	1975	1986	
I18(I18-I18)	I21	I20	?	B	1979 ^b	1979 ^a	1979	1986	
I18(I18-I18)	I52	I20	?	B	1986 ^b	1986 ^a	1986	1986	
I18(I18-I18)	I07	I18	F	J	1968 ^m	1968 ^c	1975	1986	
I18(I18-I18)	I48	I07	?	B	1983 ^e	1983 ^b	1985	1986	
I18(I18-I18)	I49	I18	?	B	1976 ^c	1976 ^b	1979	1986	
I18(I18-I18)	I24	I18	?	B	1980 ^b	1980 ^a	1980	1986	
I18(I18-I18)	I53	I18	?	B	1986 ^b	1986 ^a	1986	1986	
I18(I17-I17)	I17		F	A	≤ 1960 ^o	1959 ^d	1975	1986	
I18(I17-I17)	I26	I17	?	B	1975 ^b	1975 ^a	1975	1986	
I18(I17-I17)	I38	I17	?	B	1979-80 ^e	1979-80 ^b	1980	1986	
I18(I17-I17)	I50	I17	?	B	1982-3 ^e	1982-3 ^b	1985	1986	
I31(I31-I31)	I31		F	A	≤ 1948 ^o	1946 ^d	1968	1987	
I31(I31-I31)	I32	I31	M	J	1963 ^m	1963 ^b	1975	1987	
I31(I31-I31)	I33	I31	F	J	1970 ^m	1970 ^c	1975	1987	
I31(I31-I31)	I45	I33	?	B	1985 ^b	1985 ^a	1985	1987	
I31(I31-I31)	I35	I31	?	J	1974 ^c	1974 ^b	1975	1987	
I31(I31-I31)	I36	I31	?	B	1980 ^c	1980 ^b	1981	1987	
I31(I31-I31)	I46	I31	?	B	1985 ^b	1985 ^a	1985	1987	
R01(R05-R05)	R05		F	A	≤ 1950 ^o	1948 ^d	1975	1987	
R01(R05-R05)	R19	R05	?	B	1975 ^b	1975 ^a	1975	1986	1986
R01(R05-R05)	R20	R05	?	B	1979 ^e	1979 ^b	1982	1987	
R01(R05-R05)	R24	R05	?	B	1987 ^b	1987 ^a	1987	1987	
R01(R05-R07)	R17		F	A	1965 ^e	1965 ^b	1975	1987	
R01(R05-R05)	R23	R17	?	B	1985 ^b	1985 ^a	1985	1987	
R01(R05-R18)	R04	R05 ^d	F	J	1965 ^c	1965 ^b	1975	1987	
R01(R05-R18)	R22	R04	?	B	1984 ^c	1984 ^b	1985	1987	
R01(R05-R18)	R18	R05	F	J	1967 ^m	1967 ^c	1975	1987	
R01(R05-R18)	R21	R18	M	B	1982 ^b	1982 ^a	1982	1987	
R01(R05-R18)	R25	R18	?	B	1987 ^b	1987 ^a	1987	1987	
R01(R01-R01)	R09		F	A	≤ 1931 ^o	1923 ^d	1975	1987	
R01(R01-R01)	R07	R09 ^a	F	A	≤ 1946 ^o	1944 ^d	1975	1987	
R01(R01-R01)	R08	R07	M	J	1961 ^m	1961 ^b	1975	1982	1982
R01(R01-R01)	R11	R07	?	J	1973 ^c	1973 ^b	1975	1975	1975-80
R01(R01-R01)	R13	R07	?	B	1979 ^e	1979 ^b	1981	1987	
R01(R01-R01)	R01	R09	M	A	≤ 1954 ^p	≤ 1954 ⁱ	1975	1987	
R01(R01-R01)	R10	R09	M	J	1956 ^m	1956 ^b	1975	1975	1975-8
R01(R01-R02)	R02		F	A	≤ 1941 ^o	1938 ^d	1975	1987	
R01(R01-R02)	R03	R02	M	J	1956 ^m	1956 ^b	1975	1987	
R01(R01-R02)	R12	R02	M	J	1966 ^m	1966 ^b	1975	1987	
R01(R01-R02)	R06		M	A	≤ 1954 ^p	≤ 1954 ⁱ	1975	1987	
R01(R01-R14)	R14		M	A	≤ 1954 ^p	≤ 1954 ⁱ	1975	1987	
R01(R01-R14)	R15		M	J	1963 ^m	1963 ^b	1975	1987	
W01(W01)	W03		F	A	≤ 1943 ^o	1940 ^d	1979	1987	
W01(W01)	W01	W03	M	A	≤ 1958 ^p	≤ 1958 ⁱ	1979	1983	1983
W01(W01)	W02	W03	M	J	1960 ^m	1960 ^b	1979	1987	
W01(W01)	W05	W03	M	J	1974 ^c	1974 ^b	1979	1987	
Unknown	B04		M	J	1962 ^e	1962 ^b	1973	1973	1973

[APPENDIX LEGENDS]

Cole's association index (CAI) dendrograms showing intra-pod (matrilineal) groups (top); matrix of CAI values (middle) and genealogical trees (bottom) for all years pooled. The alpha-numeric codes above each intra-pod group represent their names and the height of the bar the level at which the group links to another intra-pod group. All adult females are underlined in the CAI matrices. CAI values for individuals that were included in the dendrograms, but not in the matrices, are indicated by x's in the matrices. Solid lines in the genealogical trees denote positive genealogies, dashed lines highly probable genealogies and dotted lines probable genealogies. The sexes of individuals that matured prior to or during the study are given in the genealogical trees. The oldest offspring are usually positioned to the left. The placement order of the Appendix Figs is the same as that given in text Figs 4-5.

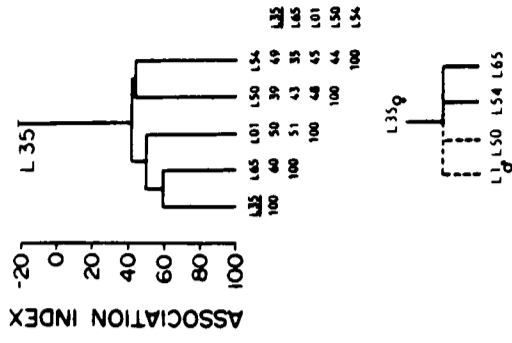

Fig. D. Genealogy of subpod L35.

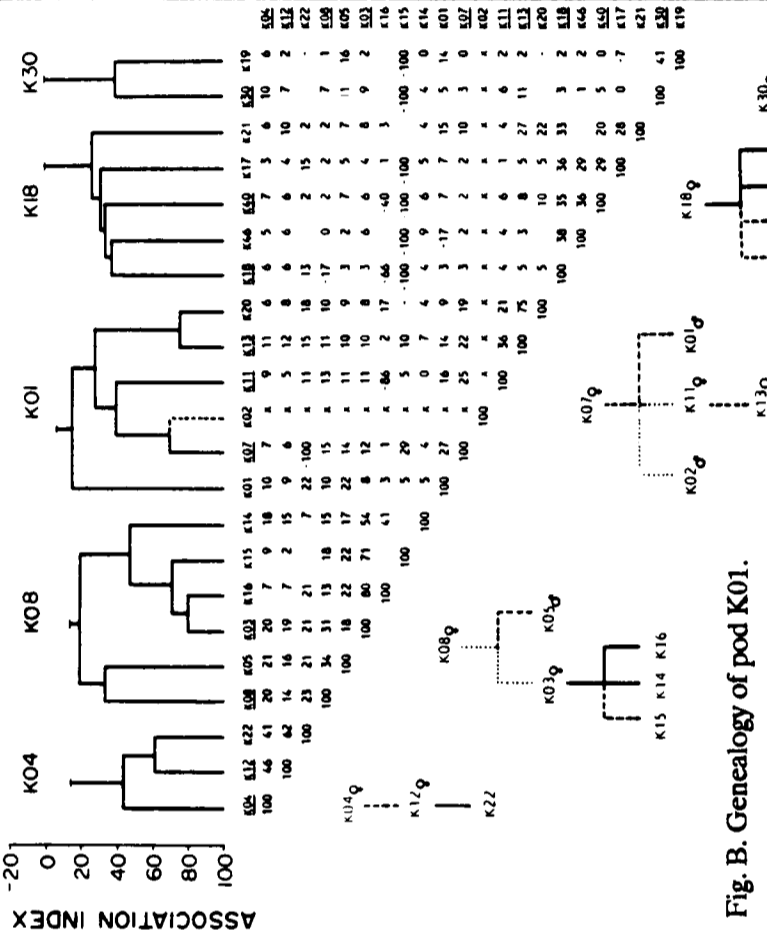

Fig. B. Genealogy of pod K01.

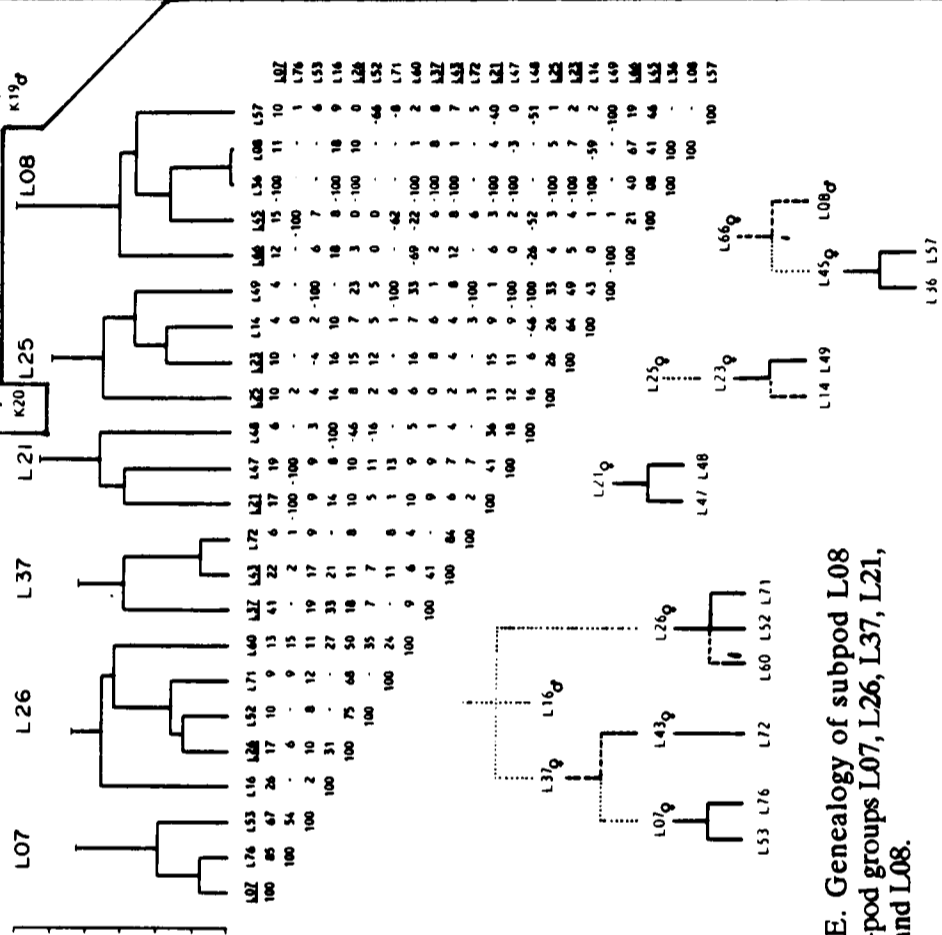

Fig. E. Genealogy of subpod L08 intra-pod groups L07, L26, L37, L21, L25 and L08.

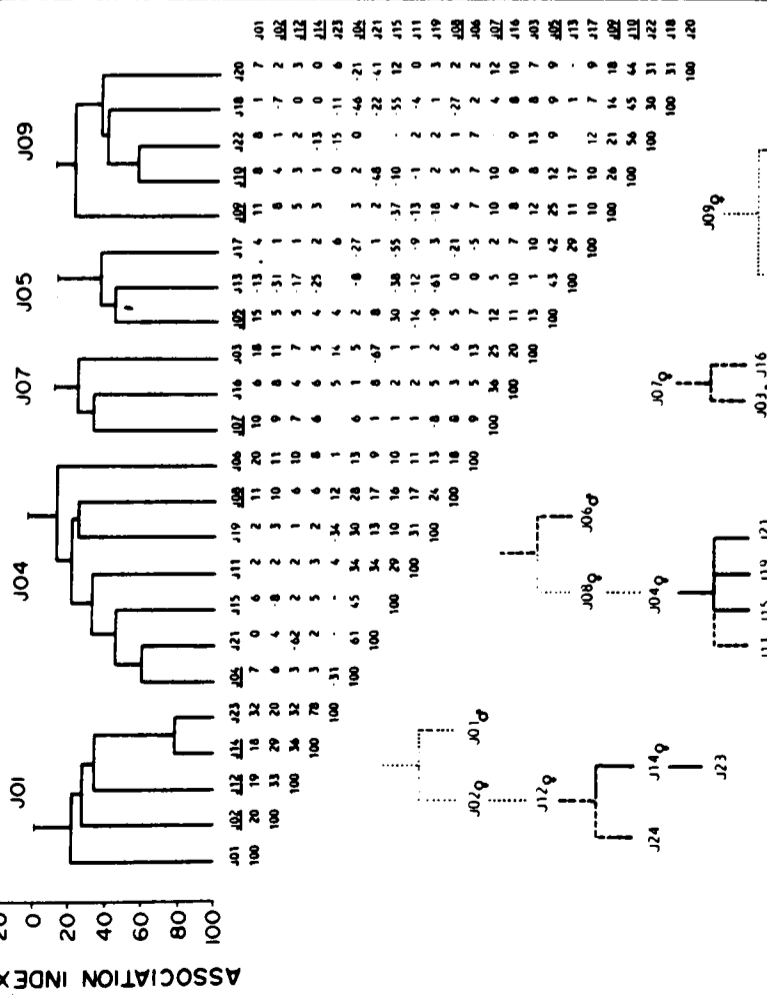

Fig. A. Genealogy of pod J01.

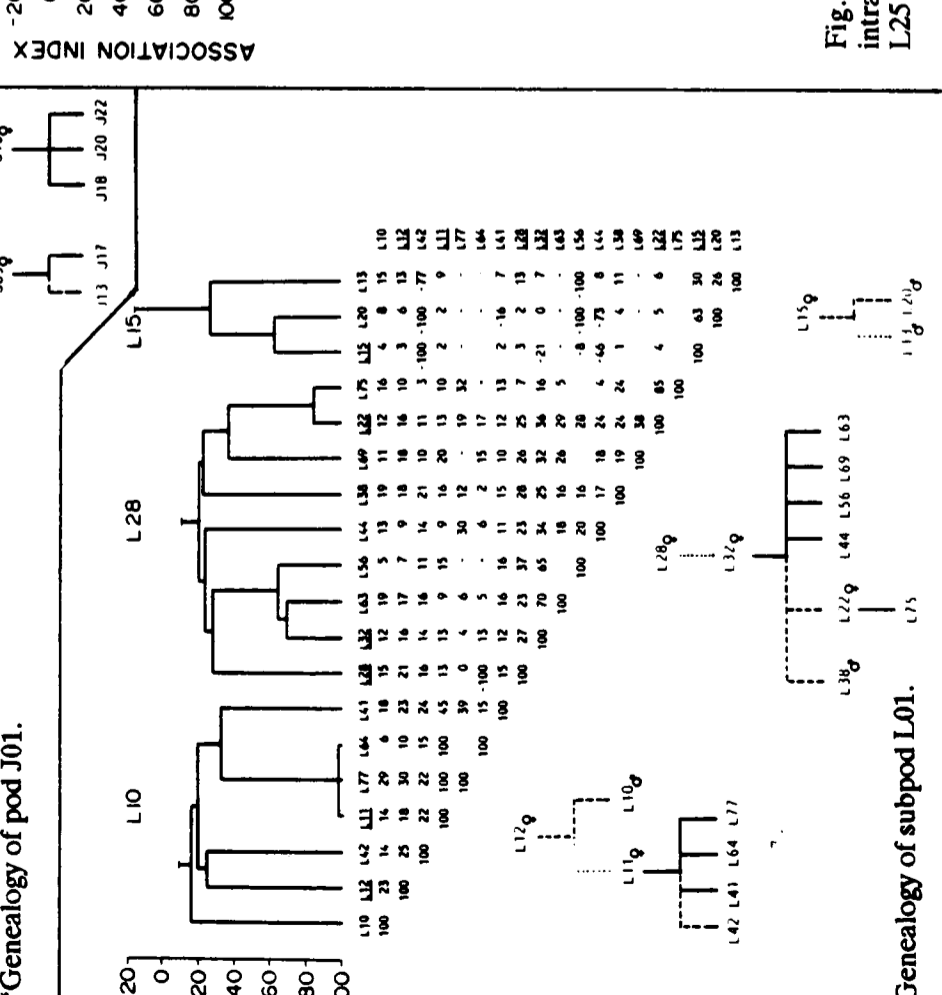

Fig. C. Genealogy of subpod L01.

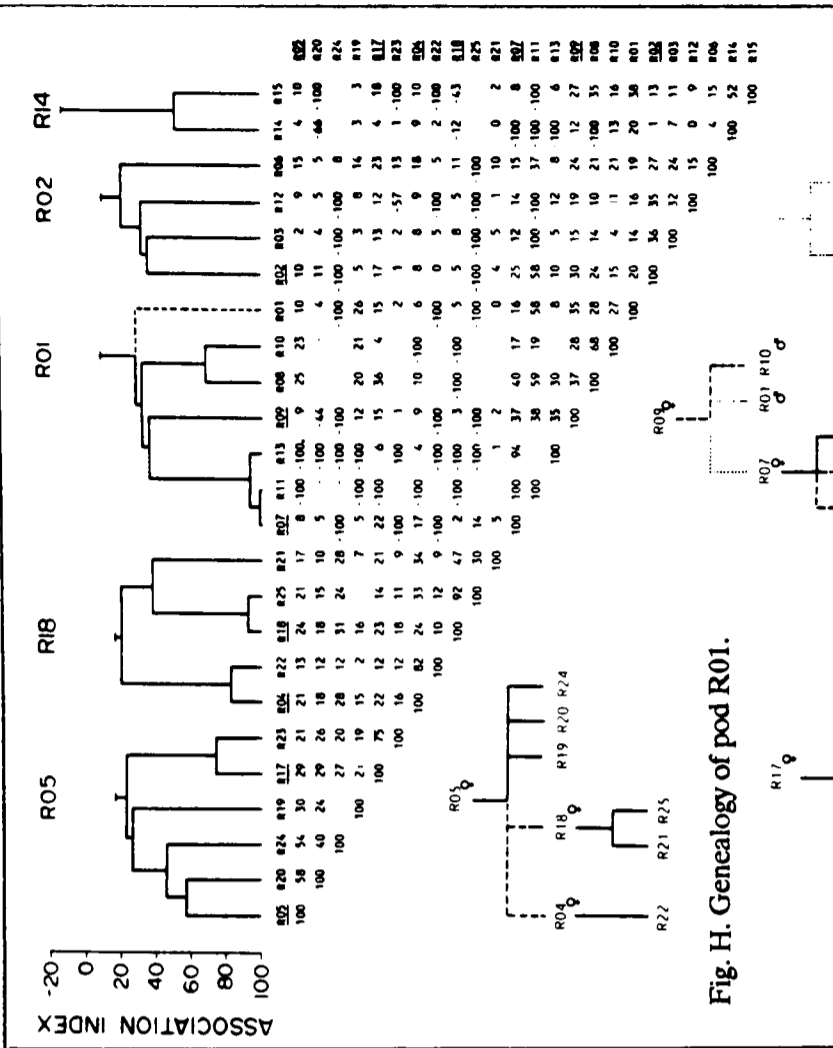

Fig. H. Genealogy of pod R01.

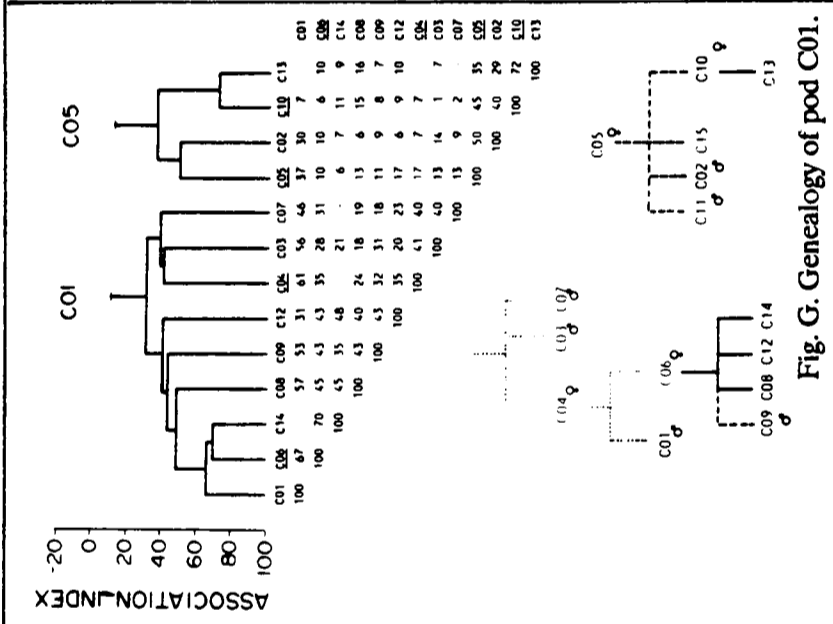

Fig. G. Genealogy of pod C01.

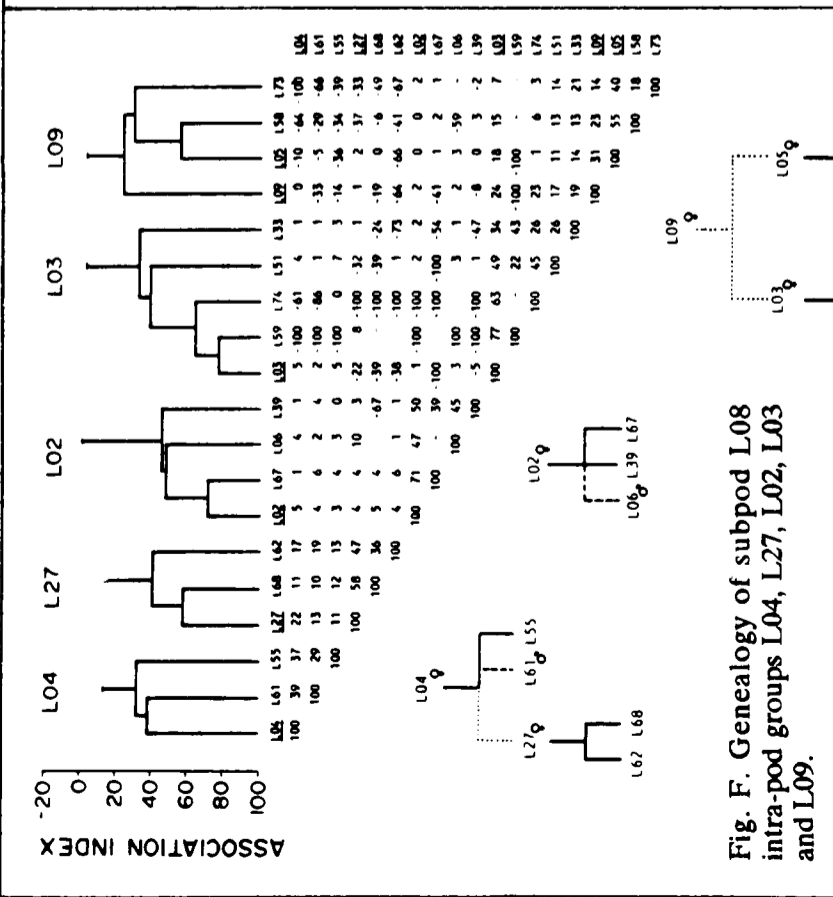

Fig. F. Genealogy of subpod L08 intra-pod groups L04, L27, L02, L03 and L09.

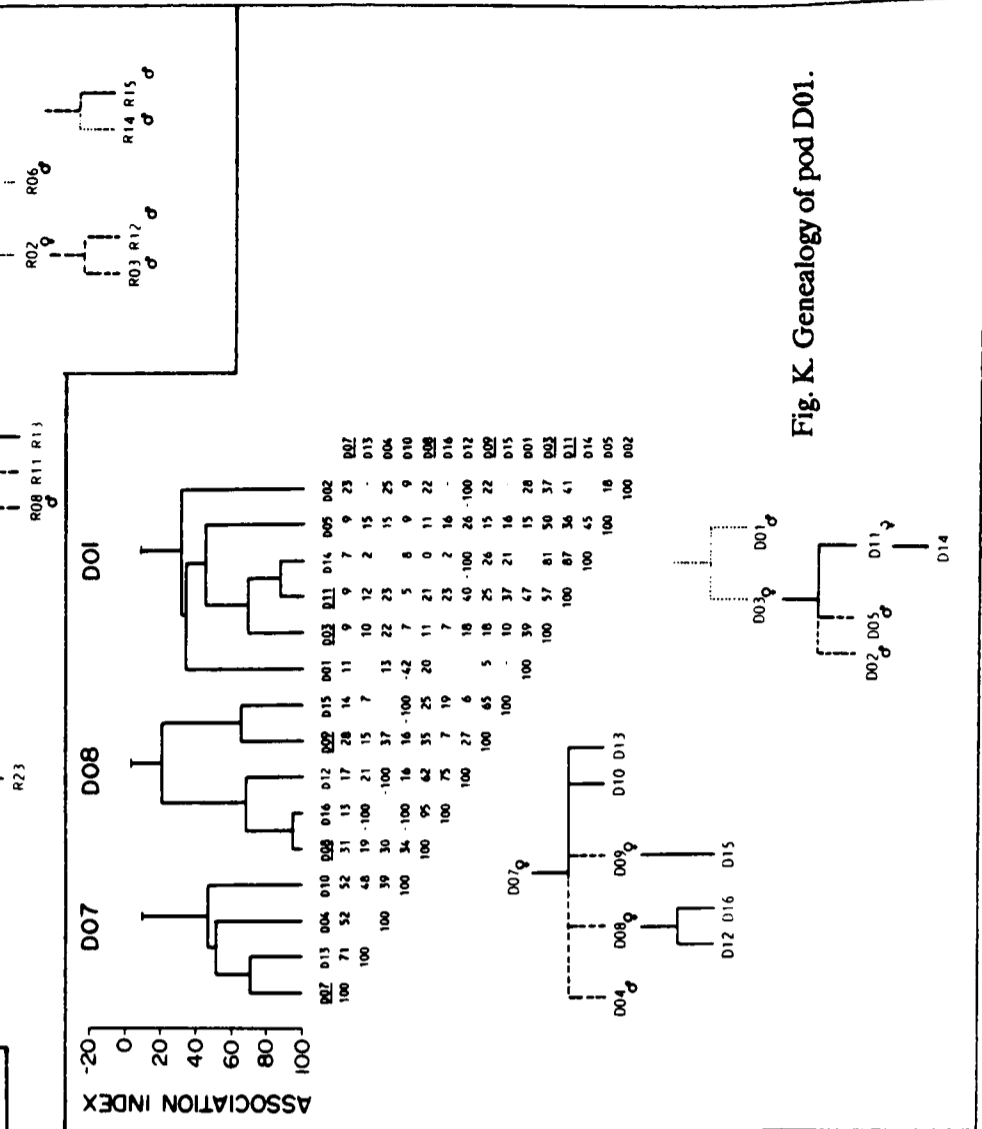

Fig. K. Genealogy of pod D01.

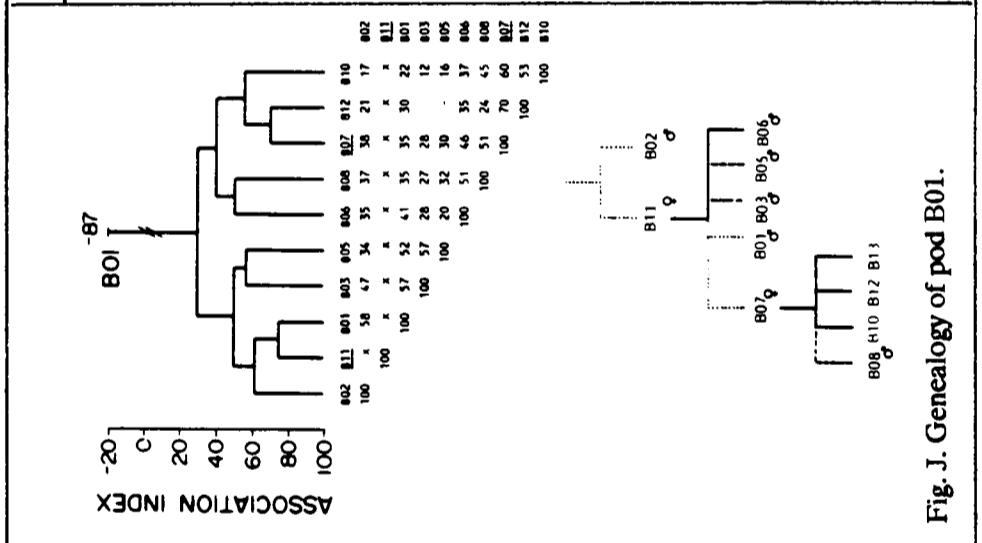

Fig. J. Genealogy of pod B01.

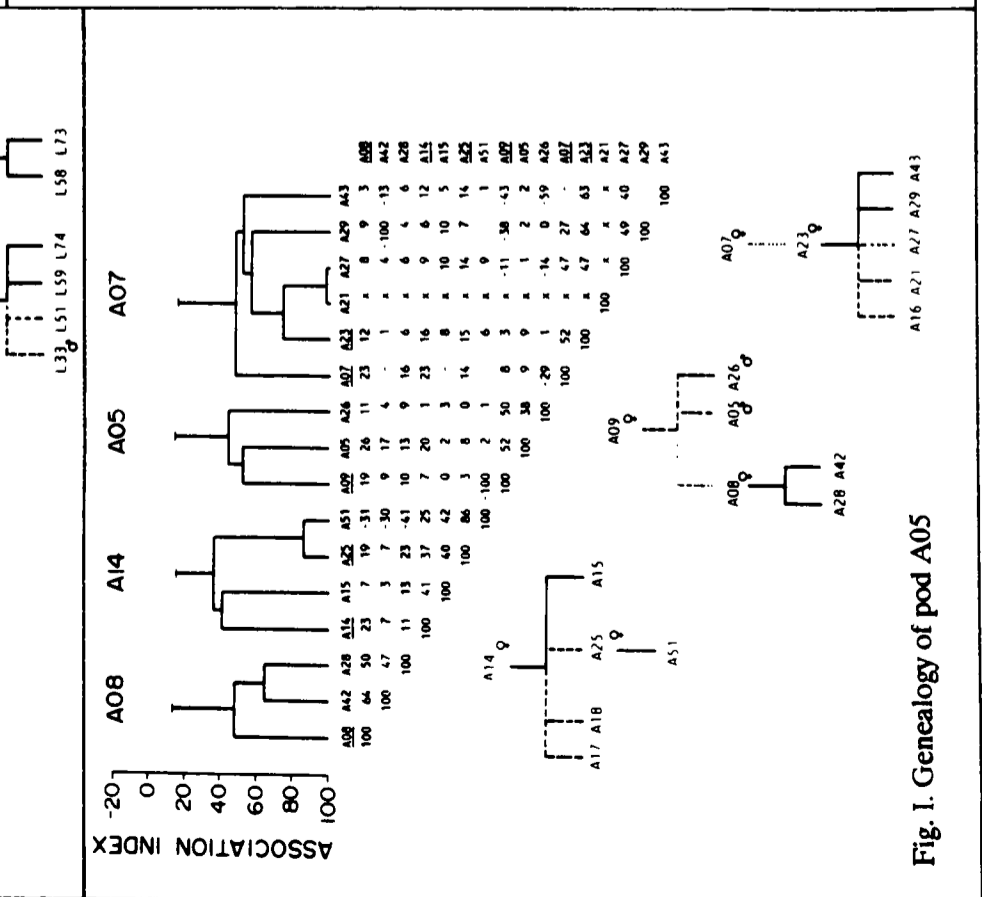

Fig. I. Genealogy of pod A05.

